

TEAC®

SERVICE MANUAL

MV-339P

Video Cassette Recorder



CAUTION

⚠ Parts marked with this sign are safety critical components. They must always be replaced with identical components—refer to the appropriate parts list and ensure exact replacement.

TABLE OF CONTENTS

■ SPECIFICATIONS	4
■ STANDARD MAINTENANCE	5
1. SERVICE SCHEDULE OF COMPONENT	5
2. CLEANING	5
■ SERVICE JIG AND TOOLS	6 – 7
1. SERVICE JIG AND TOOLS	6
2. HOW TO ASSEMBLE THE JIGS	7
■ DISASSEMBLY	8 – 20
■ ELECTRICAL MAIN PARTS LIST	21 – 23
■ TRANSISTOR ILLUSTRATION	23
■ BLOCK DIAGRAM	25 – 30
● BLOCK DIAGRAM-1 (VIDEO)	25 – 26
● BLOCK DIAGRAM-2 (SERVO/SYSTEM CONTROL)	27 – 28
● BLOCK DIAGRAM-3 (AUDIO/POWER – UNIT)	29 – 30
■ WAVE FORM – 1 (VIDEO)	31 – 35
■ IC BLOCK DIAGRAM	36
● IC, BA6209/IC, BA6219/IC, MN67481/IC, LC8992	36
■ WIRE HARNESS DIAGRAM	37 – 38
■ WIRING – 1 (VIDEO/AUDIO/SERVO/SYSCON)	39 – 40
■ SCHEMATIC DIAGRAM – 1 (VIDEO)	41 – 42
■ SYSTEM SWITCH MODE	43
■ WAVE FORM – 2 (SERVO)	44 – 45
■ DRUM SERVO SYSTEM TIMING CHART	45 – 46
■ SCHEMATIC DIAGRAM – 2 (SERVO/SYSTEM CONTROL)	47 – 49
■ WAVE FORM – 3 (AUDIO) (HEAD AMP)	50 – 52
■ SCHEMATIC DIAGRAM – 3 (FRONT)	54
■ SCHEMATIC DIAGRAM – 4 (AUDIO)	55 – 56
■ SCHEMATIC DIAGRAM – 5 (HEAD AMP.)	57 – 58
■ WIRING – 2 (FRONT/HEAD AMP./ MECHANISM)	59 – 60
■ SCHEMATIC DIAGRAM – 6 (POWER – UNIT)	61 – 62
■ WIRING – 3 (POWER – UNIT)	61 – 62
■ WAVE FORM – 4 (POWER – UNIT)	63
■ IC DESCRIPTION	64 – 65
1. IC, μ PD75108CW–A47 (IC101)	64 – 65
2. IC, MN67481P (IC201)	65

■ PRACTICAL SERVICE FIGURE	66
■ ELECTRICAL ADJUSTMENT	67 – 69
1. SERVO CIRCUIT ADJUSTMENT	68
(1) TRACKING ADJUSTMENT	68
(2) SWITCHING POSITION ADJUSTMENT	68
2. VIDEO CIRCUIT ADJUSTMENT	68 – 69
(1) PB Y-FM LEVEL ADJUSTMENT	68
(2) Y DELAY LEVEL ADJUSTMENT	68
(3) AGC ADJUSTMENT	68
(4) Y-FM CARRIER FREQUENCY ADJUSTMENT	69
(5) Y-FM DEVIATION ADJUSTMENT	69
(6) REC Y-FM LEVEL ADJUSTMENT	69
(7) CHROMA RECORDING CURRENT ADJUSTMENT	69
3. AUDIO CIRCUIT ADJUSTMENT	69
(1) RECORDING BIAS CURRENT ADJUSTMENT	69
■ MECHANICAL ADJUSTMENT	70 – 79
1. TAPE TRANSPORT ADJUSTMENT FLOWCHART	70
2. TAPE RUNNING POSITION ADJUSTMENT	71 – 73
3. ACE HEAD ADJUSTMENT	74
4. X VALUE ADJUSTMENT	75
5. ENVELOPE WAVE FORM ADJUSTMENT	76 – 77
6. ACE HEAD HEIGHT/ACE HEAD TILT ADJUSTMENT	78
7. ACE HEAD AZIMUTH ADJUSTMENT	79
■ EXPLODED VIEW, MECHANICAL PARTS LIST	80 – 94
● EXPLODED VIEW – 1	80 – 81
● EXPLODED VIEW – 2	82 – 83
● EXPLODED VIEW – 3	83 – 84
● EXPLODED VIEW – 4	85 – 87
● EXPLODED VIEW – 5	87 – 88
● EXPLODED VIEW – 6	88 – 90
● EXPLODED VIEW – 7	90 – 91
● EXPLODED VIEW – 8	92 – 94

SPECIFICATIONS

Recording/Playback system

Video : Rotary 2heads helical
scan system

Video signal Audio : fixed head
PAL color signal,
625lines, 50 fields

Recording/Playback time

4 hours max. with E-240 tape,
standard speed

Tape speed Standard speed, 23.39 mm/sec.

Tape width 12.65 mm

Usable cassette

VHS video cassette

RF output VHF channel 0 or 1,

B PAL output

Video input 1.0 Vp-p, 75 ohms unbalanced

Video output 1.0 Vp-p, 75 ohms unbalanced

Audio input -10 dBs, 47 kohms

Audio output -8 dBs, 2.2 kohms

Operating temperature

5°C - 40°C

Power requirements

240V AC, 50Hz

Power consumption

20 watts

Dimensions

H model : 270 (W) × 95 (H) × 355.5 (D)
mm

Weight

H model : 4.2 kg

Input/output

Audio input (AUDIO IN) :
phono jack (1)

Audio output (AUDIO OUT) :
phono jack (1)

Video input (VIDEO IN)
phono jack (1)

Video output (VIDEO OUT) :
phono jack (1)

Antenna input (AERIAL) :
IEC connector, 75 ohms (1)

Antenna output (RF OUT) :
IEC connector, 75 ohms (1)

- Design and specifications are subject to change without notice.

STANDARD MAINTENANCE

1. SERVICE SCHEDULE OF COMPONENT

○ : Check ● : Change

DECK		Periodic Service Schedule			
Ref. No.	Parts Name	1000 h	2000 h	3000 h	4000 h
2-2	UPPER DRUM	○	●	○	●
4-6	PINCH ROLLER A		●		●
3-32	CAPSTAN MOTOR ASSY		●		●
5-27	CLUTCH ASSY		●		●
4-46	LM ASSY			●	
6-22	MAIN BELT		●		●
3-5	BT BAND ASSY		●		●
5-29	DRIVE BELT		●		●
4-41	BRAKE SHOE		●		●
6-1	LOADING BELT		●		●
5-26	FL BELT			●	
2-5	DRUM EARTH			●	
4-21	ACE HEAD HV-225211			●	
3-25	REEL ASSY			●	
4-50	FULL ERASE HEAD			●	

NOTE :

1. Clean all parts for the tape transport.
Upper Drum with video head / Pinch Roller A
ACE Head / Full Erase Head

2. After cleaning up the parts, perform all DECK ADJUSTMENT.

2. CLEANING

1. CLEANING OF "VIDEO HEAD" (See Figure-1)

Head cleaning by using a chamois skin.

— Procedure —

- 1) Remove the "Cabinet, Steel".
- 2) Put on a glove (thin type) to avoid touching the "Upper drum" and "Lower drum" with bare hand.
- 3) Put a few drops of alcohol on the Chamois skin, and by slightly placing it against the "Head tip", allow the "Upper drum" to turn the right and left.

— Remark —

- 1) The video head is of very hard material, but since it is very thin, avoid cleaning it vertically.
- 2) Wait for the cleaned part to dry out, before operating the unit.
- 3) Do not reuse the Stained chamois skin.

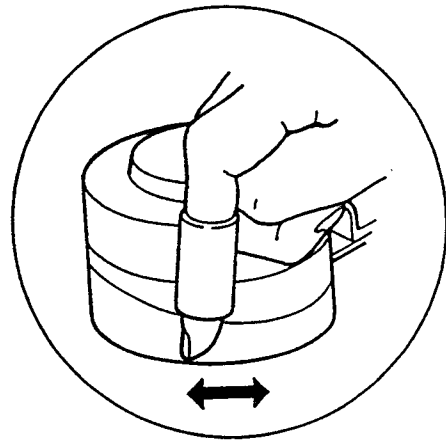

Fig-1

2. CLEANING OF "ACE HEAD" (See Figure-2)

Head cleaning by using a chamois skin.

— Procedure —

- 1) Remove the "Cabinet, Steel".
- 2) Put a few drops of alcohol on the chamois skin, clean up the "Audio control head", being careful not to damage the "Upper drum" and other tape running parts.

— Remark —

- 1) Avoid cleaning "ACE Head" vertically.
- 2) Wait for the cleaned part to dry well, before operating the unit.

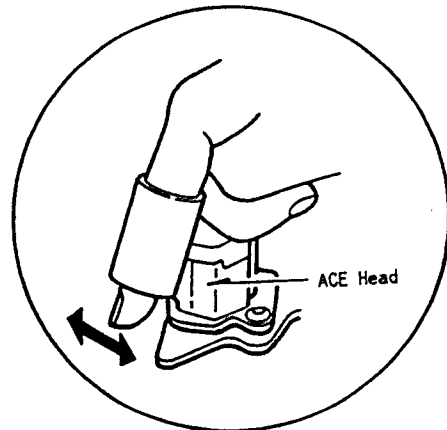

Fig-2

SERVICE JIG AND TOOLS

1. SERVICE JIG AND TOOLS

Ref. No.	Name	Adjustment
J-1	Torque Meter (FSJ-VHT-063)	Back Tension
J-2	Special Driver (SMALL)	Tape Running Position, Envelope Wave Form
J-3	Special Driver (LARGE)	X Value
J-4	Mirror	Tape Transportation Check
J-5	Alignment Tape (TTV-P2)	X Value, Envelope Wave Form, ACE Head Azimuth
J-6	Alignment Tape (TTV-P1)	ACE Head Height / ACE Head Tilt
J-7	Box Driver M3	Tape Running Position, X Value, Envelope Wave Form
J-8	EXT. PCB. KIT (A) (Parts No. 09-054-012-010)	HA (For repair of circuit board)

J-1, J-5, J-6

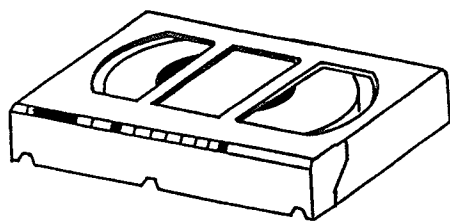

J-2, J-3

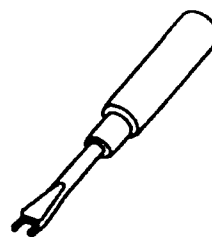

J-4

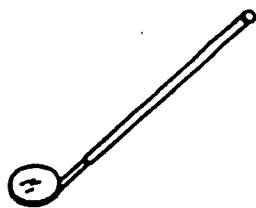

J-7

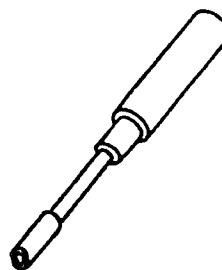

2. HOW TO ASSEMBLE THE JIGS

1. Assembling the J-8 (See Figure-1)

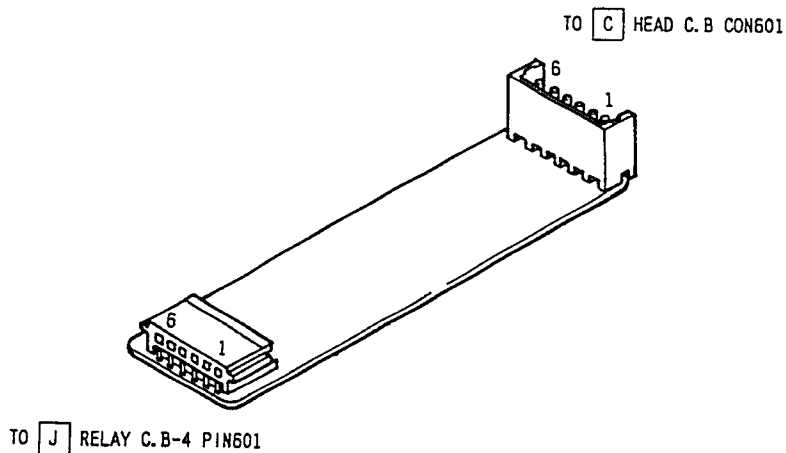

Fig-1

Place the circuit board with the solder side down as shown in the figure above and assemble the connectors, taking care of their directions.

2. Using the J-8 (See Figure-1)

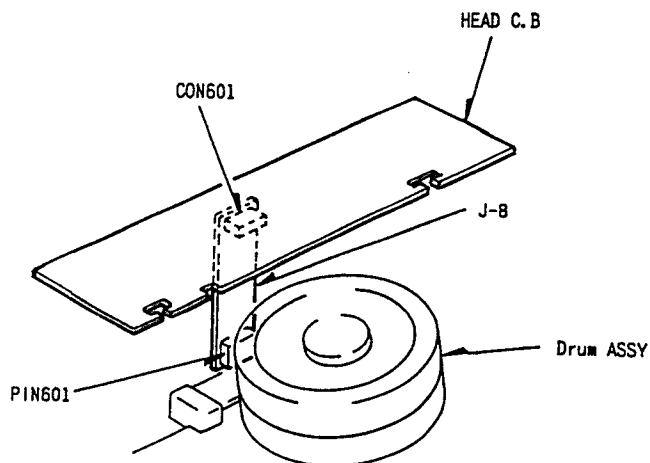

Fig-1

Use this jig when servicing the "Head circuit board".

DISASSEMBLY

1. "CABINET, STEEL" AND "CABINET FRONT ASSY" REMOVAL

(See Figure-1)

- 1) Remove 4 screws and the "Cabinet, steel".
- 2) Release 5 hooks and remove the "Cabinet front ASSY".

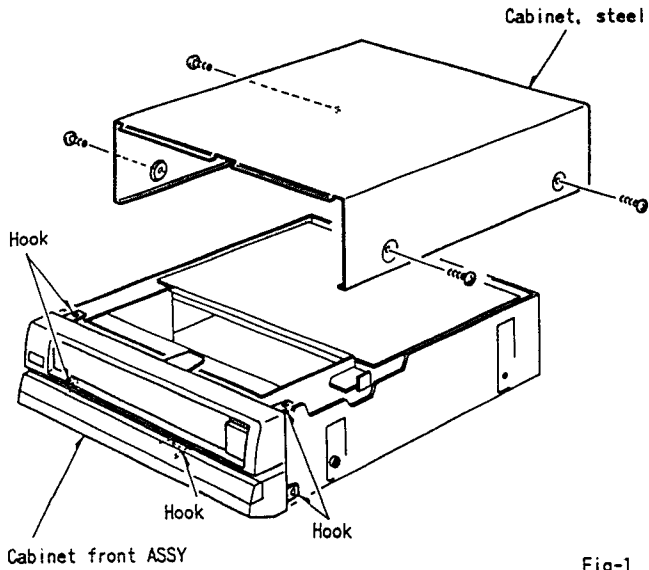

Fig-1

3. "MECHANISM ASSY" REMOVAL (See Figure-3)

- 1) Remove 1 screw (A) and the "Head C.B".
- 2) Remove 3 screws (B) holding the "Mechanism ASSY".

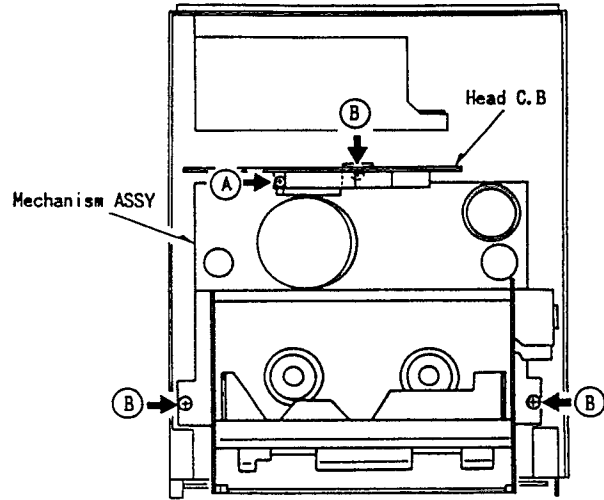

Fig-3

2. "MAIN CIRCUIT BOARD" REMOVAL (See Figure-2)

- 1) Remove 5 screws and the "Main C.B".

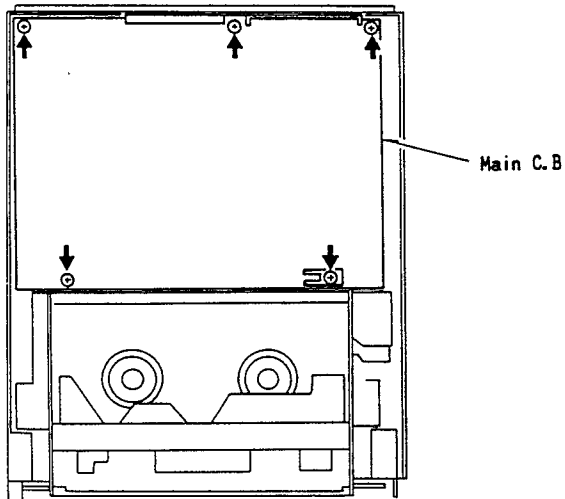

Fig-2

4. "FRONT LOADING ASSY" REMOVAL (See Figure-4)

- 1) Remove "Main belt".
- 2) Remove 4 screws (A).
- 3) Release the hooks on both sides and remove the "Front loading ASSY". (Since it is difficult to release these hooks, hold the front of the "Front loading ASSY" and shake it up and down to release them.)

5. "CASSETTE LOAD BRACKET ASSY" REMOVAL (See Figure-4)

- 1) Remove 1 screw (B).
- 2) Take off the "Cassette load bracket ASSY".

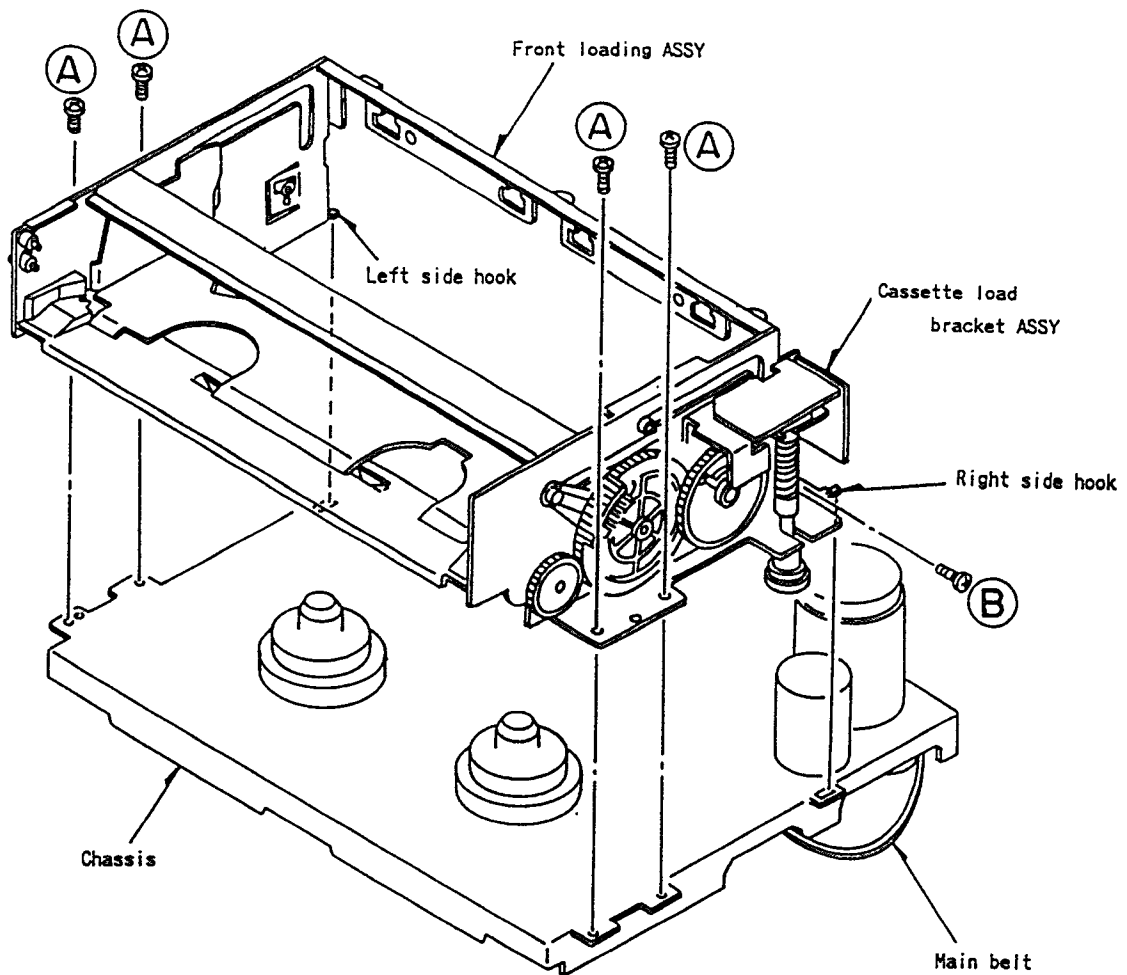

Fig-4

6. "PHOTO SENSOR ASSY" REMOVAL (See Figure-5)

1. "Lamp holder ASSY" Removal

1) Remove 1 screw (A), and take off the "T soft brake ASSY".

(At this time, never take off the "T-spring, soft brake arm".)

2) Release the "Lamp holder ASSY" from hook (a) of the chassis and turn it counterclockwise to remove it from the chassis.

2. "Switch C.B", "Sensor guide" and "End sensor C.B" Removal

1) Remove 1 screw (B) and take off the "Switch C.B".

2) Remove 1 screw (C) and take off the "Sensor guide".

3) Remove 1 screw (D) and take off the "End sensor C.B".

3. "Sensor guide" and "Start sensor C.B" Removal

1) Remove 1 screw (E) and take off the "Sensor guide".

2) Remove 1 screw (F) and take off the "Start sensor C.B".

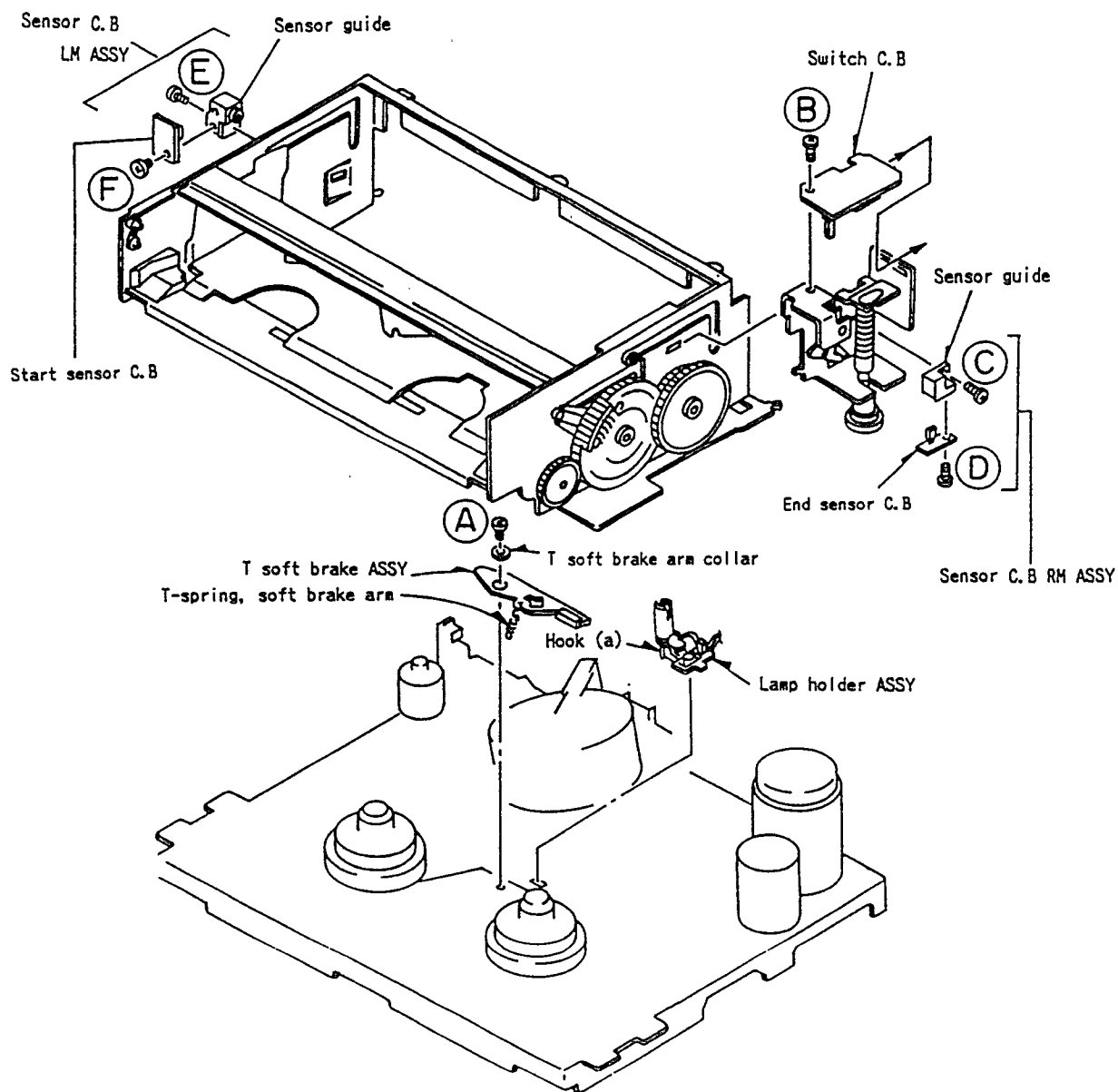

Fig-5

7. "FE PLATE" AND "ACE HEAD" REMOVAL (See Figure-6)

1. "FE plate" Removal

1) Remove Nut (A).

2) Take out the "Impedance roller" and pull up the "FE plate".

(Take care not to lose parts "Impedance roller", "Impedance roller sleeve", "Tape guide frange A", "Tape guide flange spring" and "Plane washer 3×8×0.5" at the time of the "FE plate" removal.)

3) Remove 1 screw (B) and take off the "Full erase head".

2. "ACE head" Removal

1) Remove 3 screws (C×1, D×1, E×1) and "Azimuth spring".

2) Remove "ACE head".

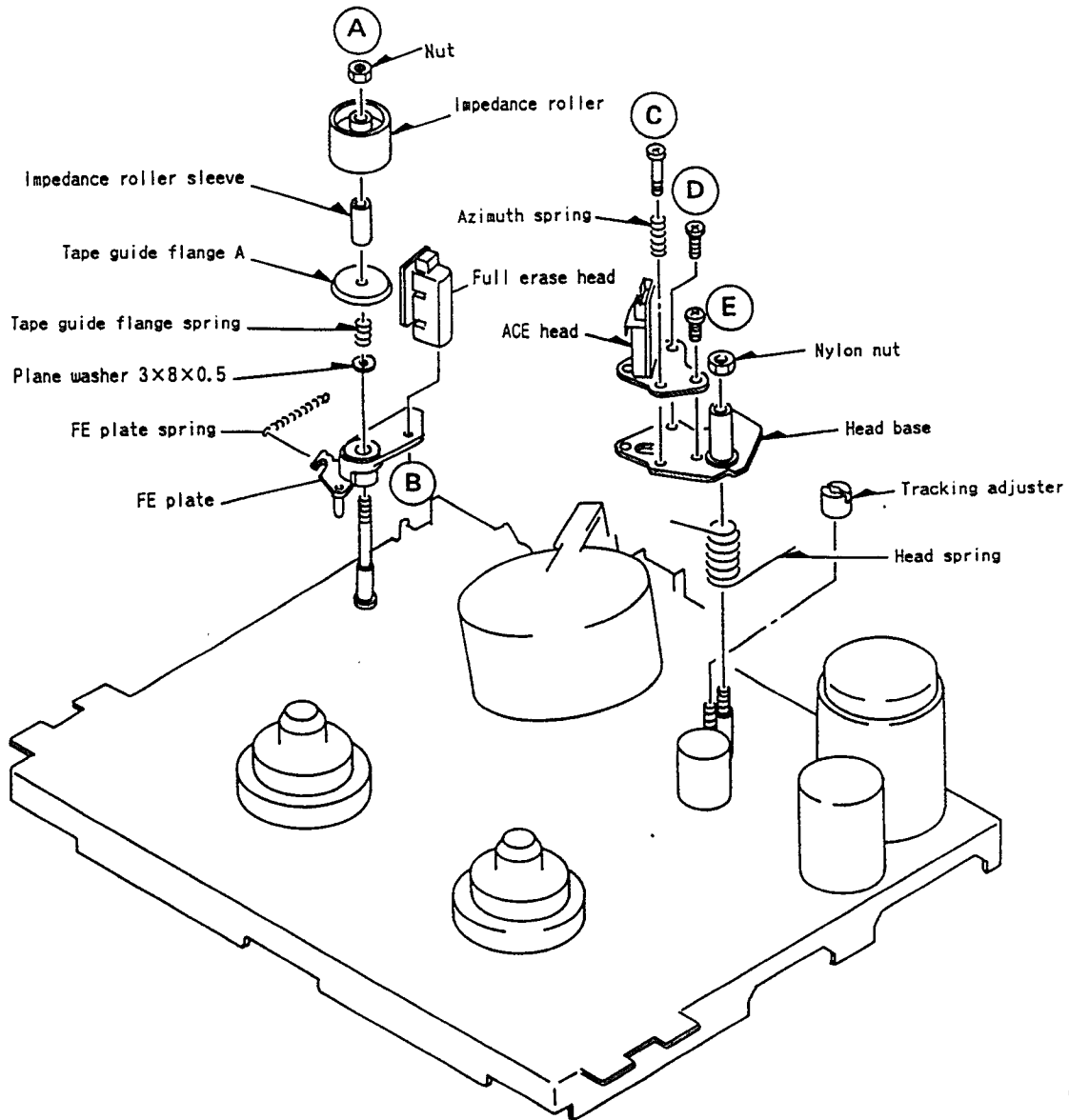

Fig-6

8. "GEAR HOLDER ASSY" REMOVAL (See Figure-7)

- 1) Remove the "Front loading ASSY".
- 2) Remove "Drive belt".
- 3) Remove Poly-Washer and "Middle pulley ASSY".
- 4) Remove Nylon-Washer (A) and take off the "Clutch ASSY".
- 5) Remove 1 screw (B) and 2 screws (C) and take off the "Gear holder ASSY".
- 6) Remove 1 screw (D) and take off the "T-spring, soft brake arm".
- 7) Take off the "T soft brake ASSY".
- 8) Remove 2 "E-Rings (E)" and take off the 2 "Reel drive gear".

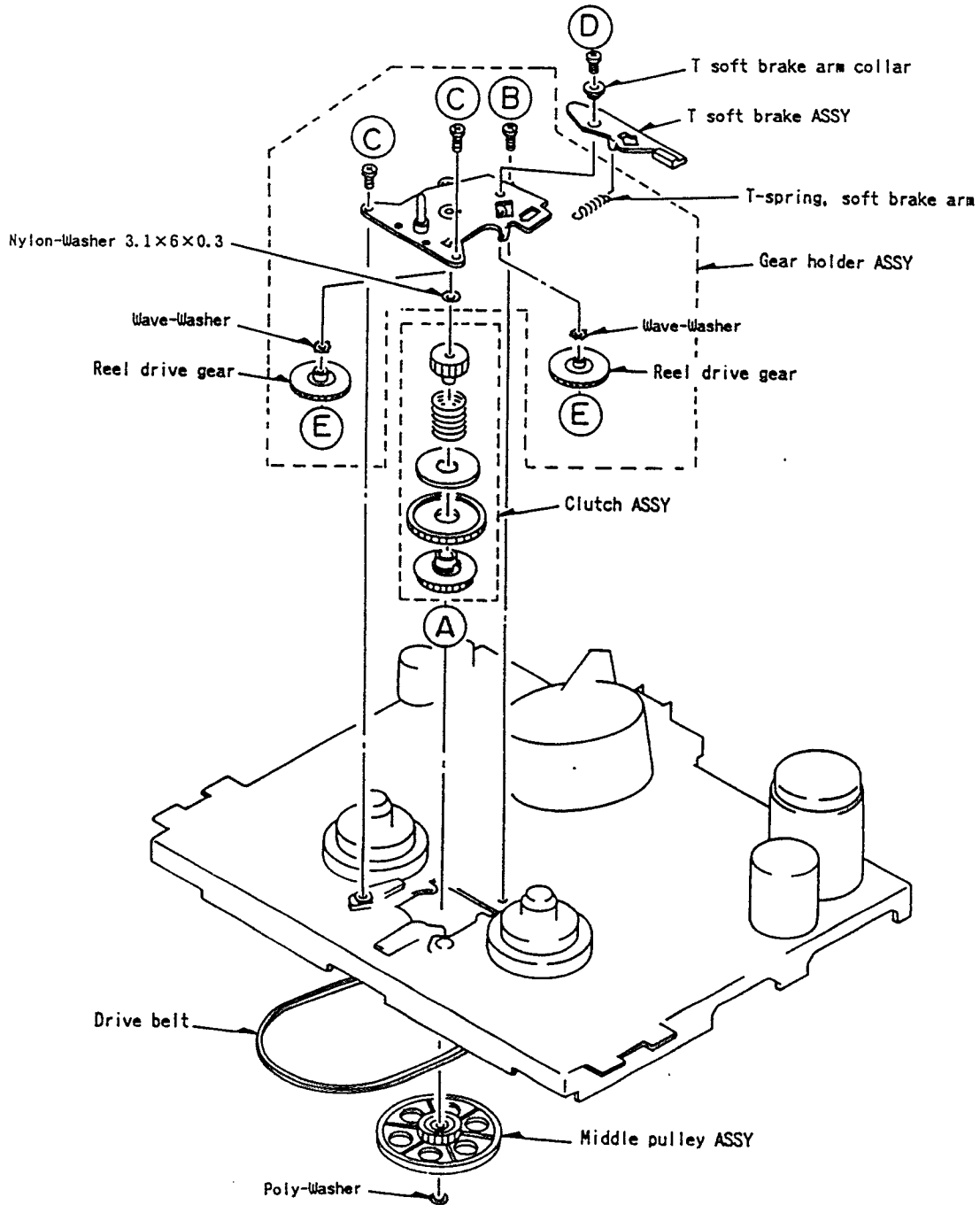

Fig-7

9. "BT BAND ASSY" AND "BT ARM SEMI ASSY" REMOVAL (See Figure-8)

- 1) Remove the "Front loading ASSY".
- 2) Remove Poly-Washer (A) and "BT actuate plate spring" from the "BT arm semi ASSY".
- 3) Remove 1 screw (B) and "Band holder spring".
- 4) Take off the "BT band ASSY" from the "BT arm semi ASSY".

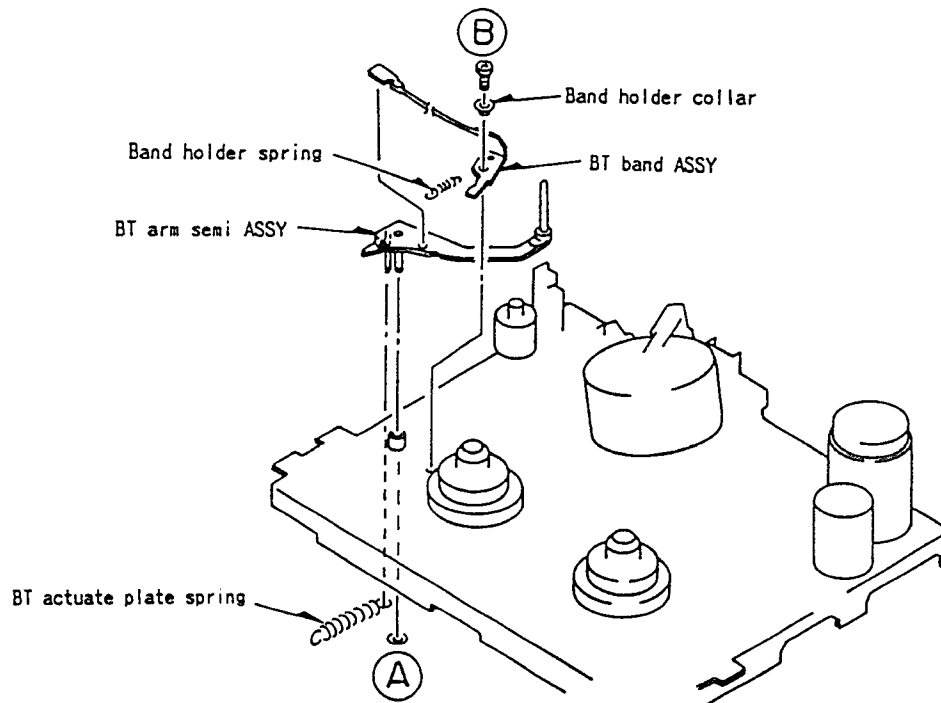

Fig-8

10. "REEL ASSY" REMOVAL (See Figure-9)

- 1) Remove the "Front loading ASSY", "Gear holder ASSY" and "BT band ASSY".
- 2) Remove 1 screw (A) and the "Back tension support".
- 3) Remove the 2 "Reel ASSY".

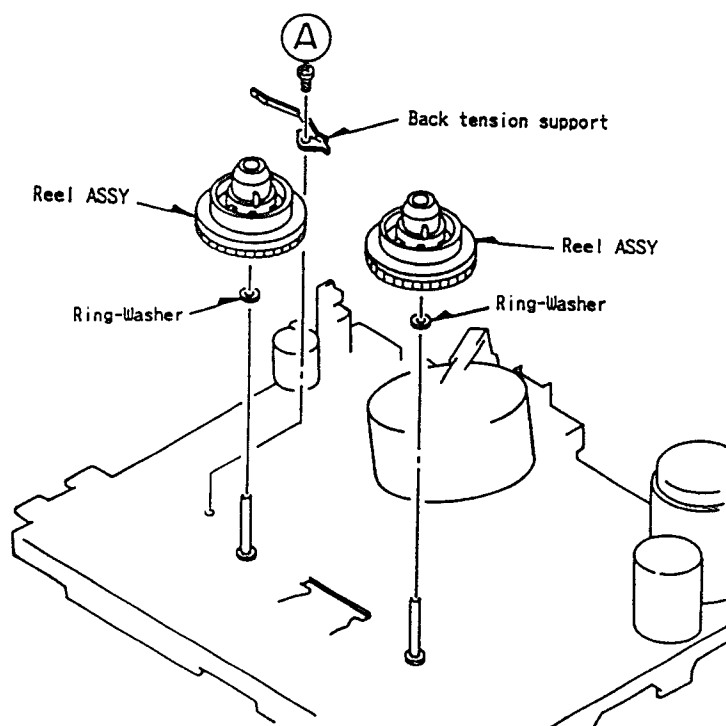

Fig-9

11. "CYLINDER ASSY" REMOVAL (See Figure-10)

- 1) Remove the "Front loading ASSY".
- 2) Pull out the "RELAY C.B-1" from the "Cylinder motor TM82".
- 3) Remove 1 screw (A) and take off the "Drum earth".
- 4) Remove 3 screws (B) and take off the "Cylinder ASSY".

≡Remarks≡

Take off the "Cylinder ASSY" carefully without any damage.

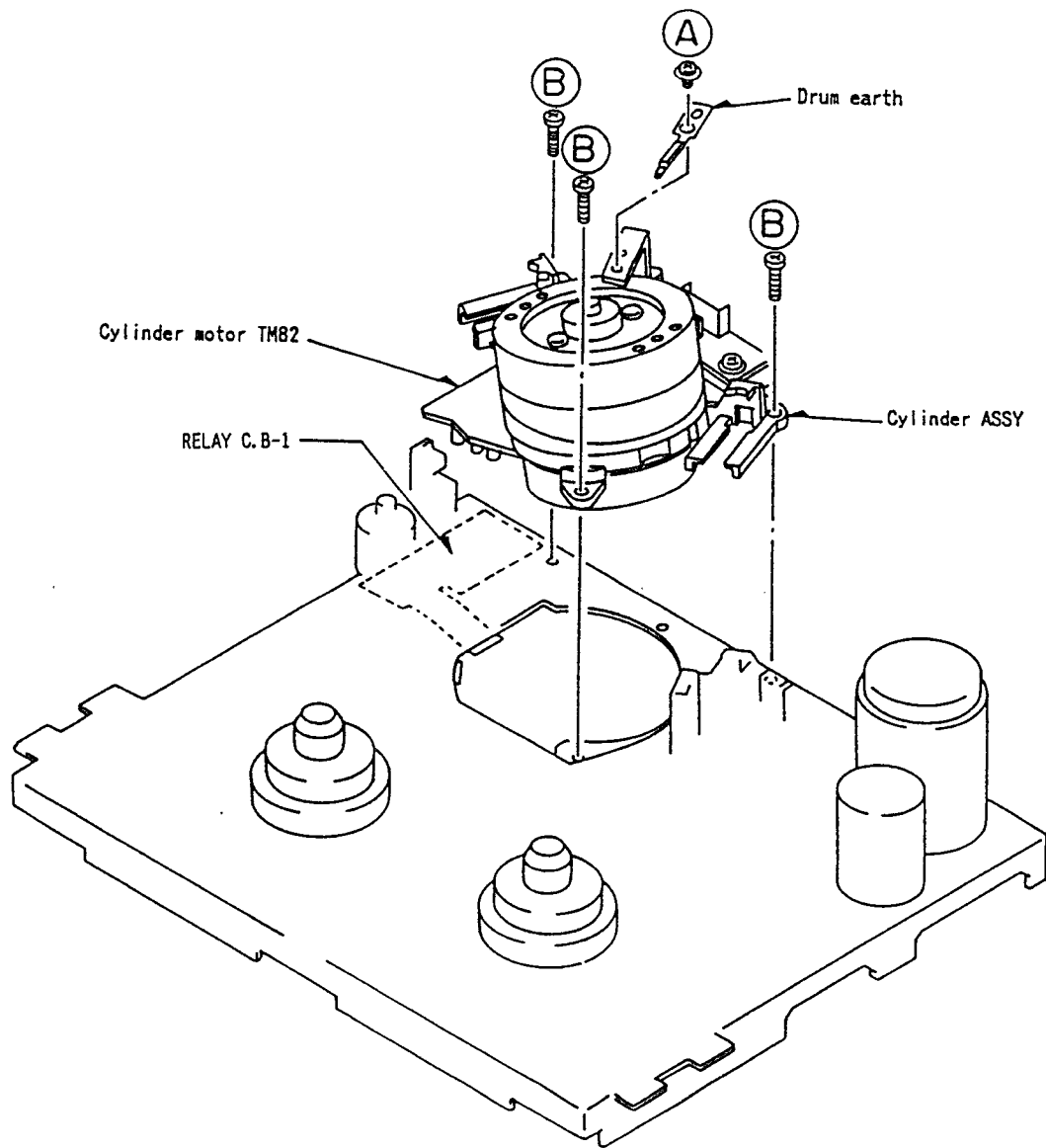

Fig-10

12. "UPPER DRUM" REMOVAL (See Figure-11)

- 1) Remove the "Front loading ASSY".
- 2) Remove 1 screw (A) and take off the "Drum earth bracket".
- 3) Remove 2 screws (B) and take off the "Upper drum".

≡Remark≡

1. Use gloves and do not touch the drum surface with bare fingers.
2. If the Video head is defective, replace the complete "Upper drum" with the Head.

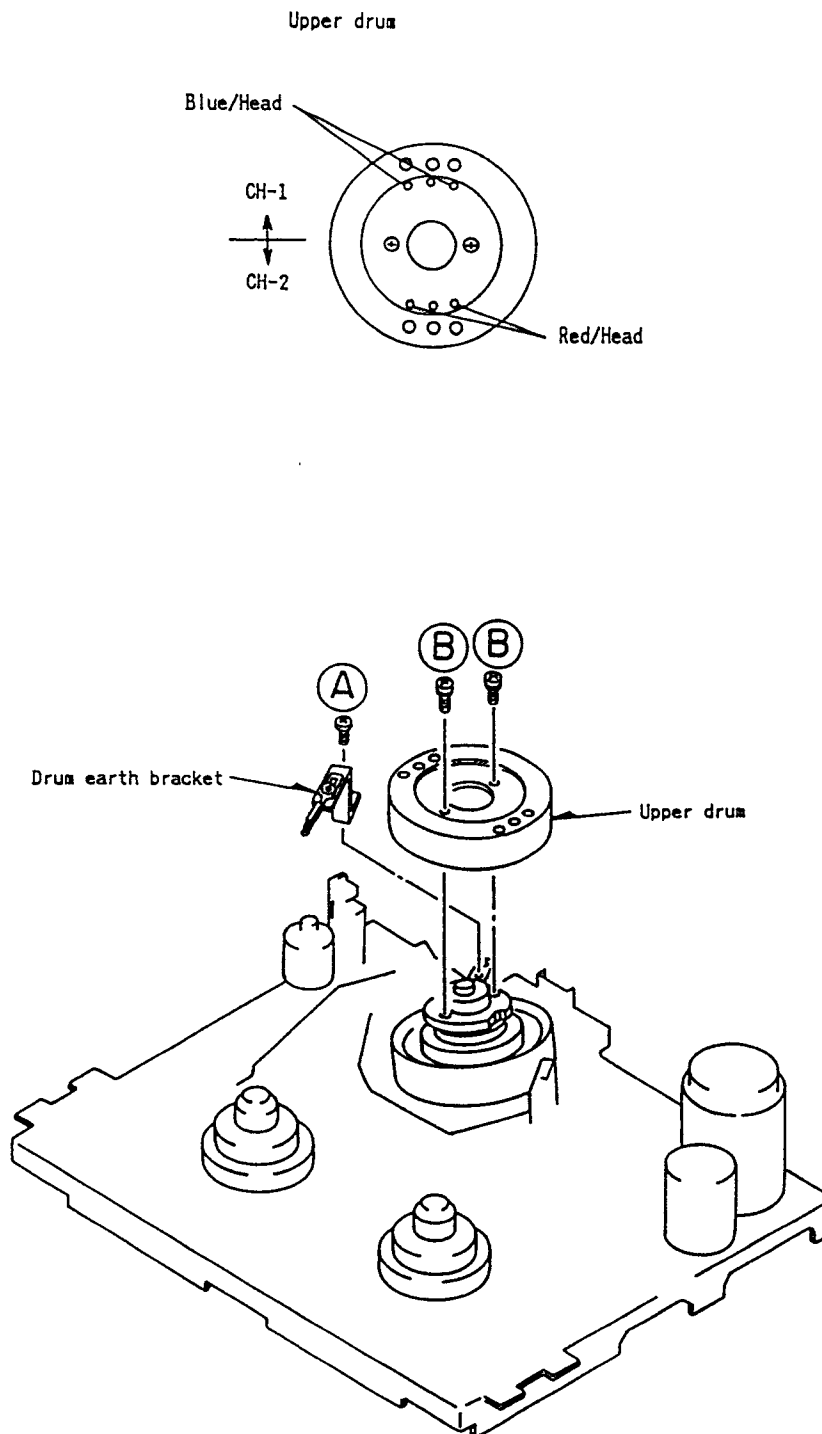

Fig-11

13. "CYLINDER MOTOR" REMOVAL (See Figure-12)

- 1) Pull out the "RELAY C.B-1" from the "Cylinder motor TM82".
- 2) Remove 2 screws (A) and take off the "Cylinder motor TM82".
- 3) Remove 3 screws (B) and take off the "Cylinder motor TM82".

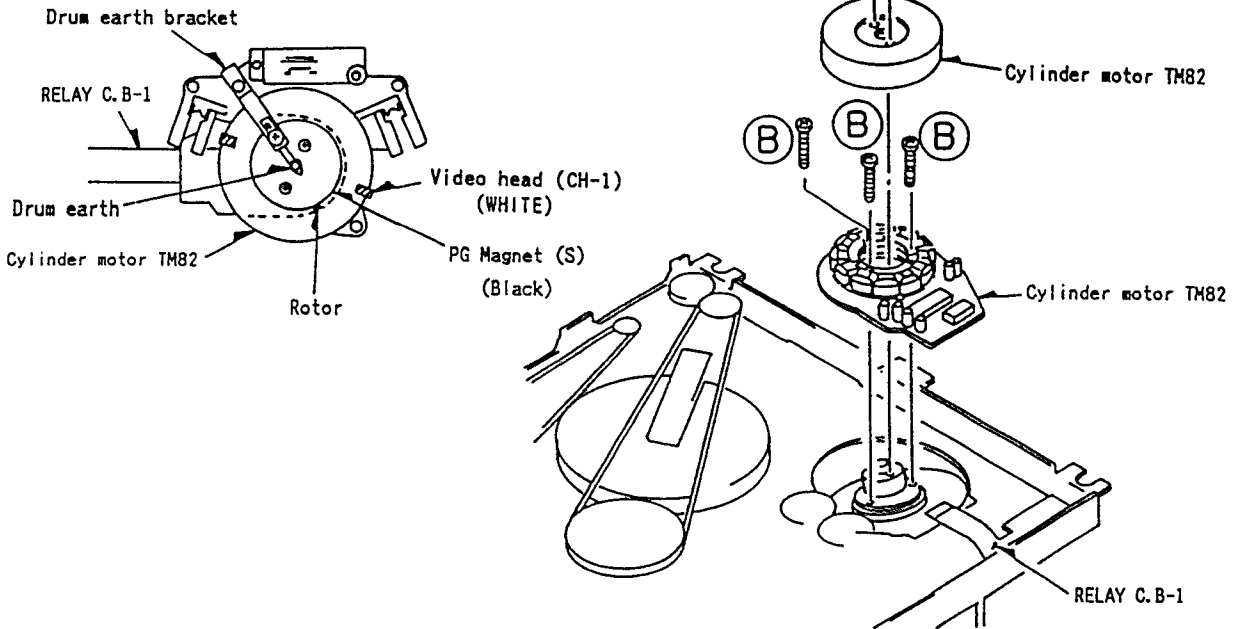

Fig-12

14. "CAPSTAN MOTOR ASSY" AND "LOADING MOTOR ASSY" REMOVAL (See Figure-13)

1. "Capstan Motor ASSY" Removal

- 1) Take off the "Drive belt" and "Main belt".
- 2) Remove 2 screws (A) and take off the "Capstan motor ASSY".

2. "LOADING MOTOR ASSY" Removal

- 1) Take off the "FL belt".
- 2) Remove 2 screws (B) and take off the "Loading motor ASSY".

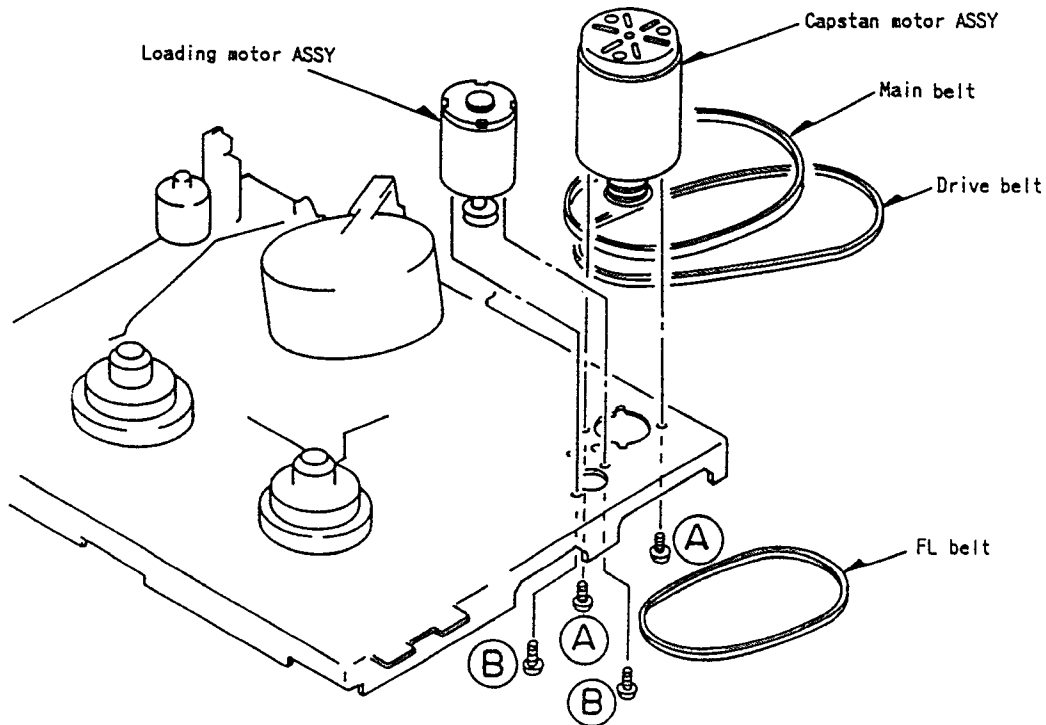

Fig-13

15. "LOADING GEAR" AND "LOADING CAM ASSY" REMOVAL (See Figure-14)

- 1) Take off the "Loading belt" from the "Loading pulley".
- 2) Remove Poly-Washer (A) and take off the "Loading pulley".
- 3) Remove Poly-Washer (B) and take off the "Loading gear".
- 4) Remove Poly-Washer (C) and take off the "Eject arm" and the "Brake actuate arm".
- 5) Remove 2 screws (D), and take off the "Loading lever reinforce plate" and the "Loading lever ASSY".
- 6) Take off the "Loading cam ASSY".

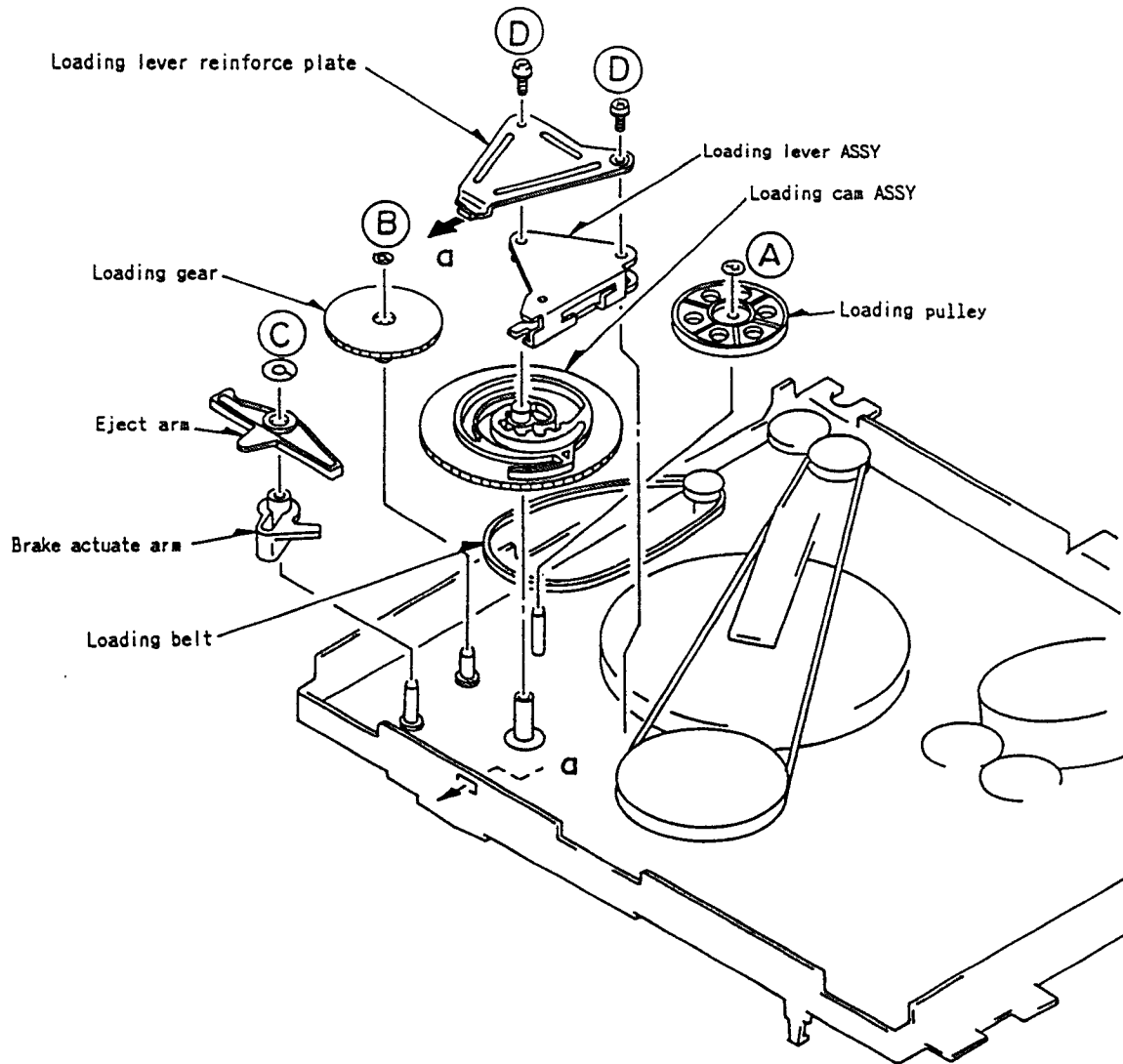

Fig-14

16. "FLYWHEEL CAPSTAN" REMOVAL (See Figure-15)

- 1) Remove the Nylon-Washer (A).
- 2) Take off the "Drive belt" and "Main belt".
- 3) Remove 2 screws (B) and take off the "FL angle ASSY".
- 4) Take off the "Flywheel capstan".

≡Remark≡

Do not miss the Poly-Washer (C) when pulling out the "Flywheel capstan".

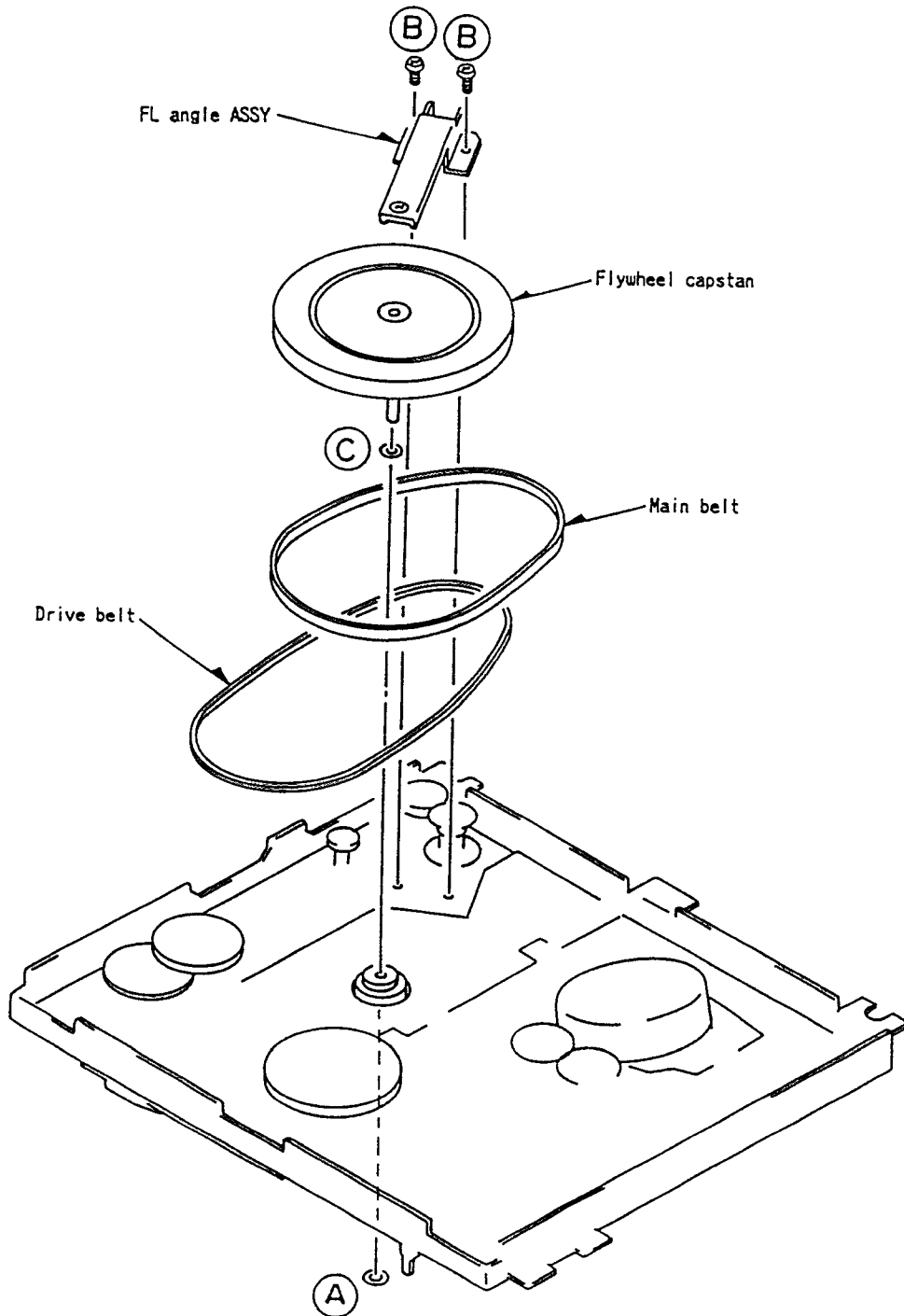

Fig-15

17. "REEL SENSOR" REMOVAL (See Figure-16)
1. Remove "Front loading ASSY" and the "Gear holder ASSY".
 2. Remove "Reel ASSY".
 3. Remove "Reel sensor".

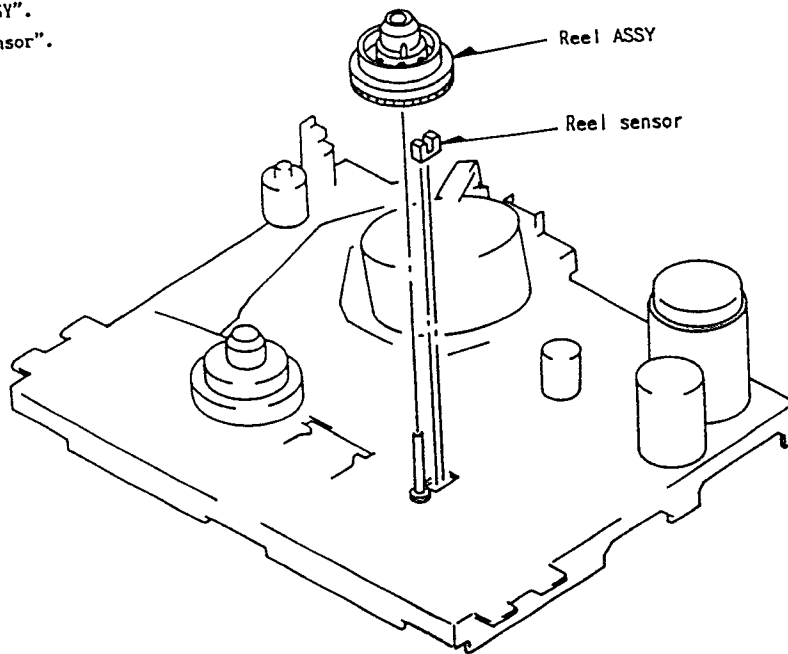

Fig-16

18. "LOADING BASE SEMI ASSY" REMOVAL (See Figure-17)
- 1) Remove "Cylinder ASSY", "BT arm semi ASSY", "BT band ASSY" and "Front loading ASSY".
 - 2) Remove 1 screw (A) and "L gear plate collar", "L gear plate".
 - 3) Remove 2 screws (B).
 - 4) Take off the "Loading base semi ASSY".

≡Remark≡

When installing the "L gear plate", align markings (C) on the "T loading gear L" and "L gear plate".

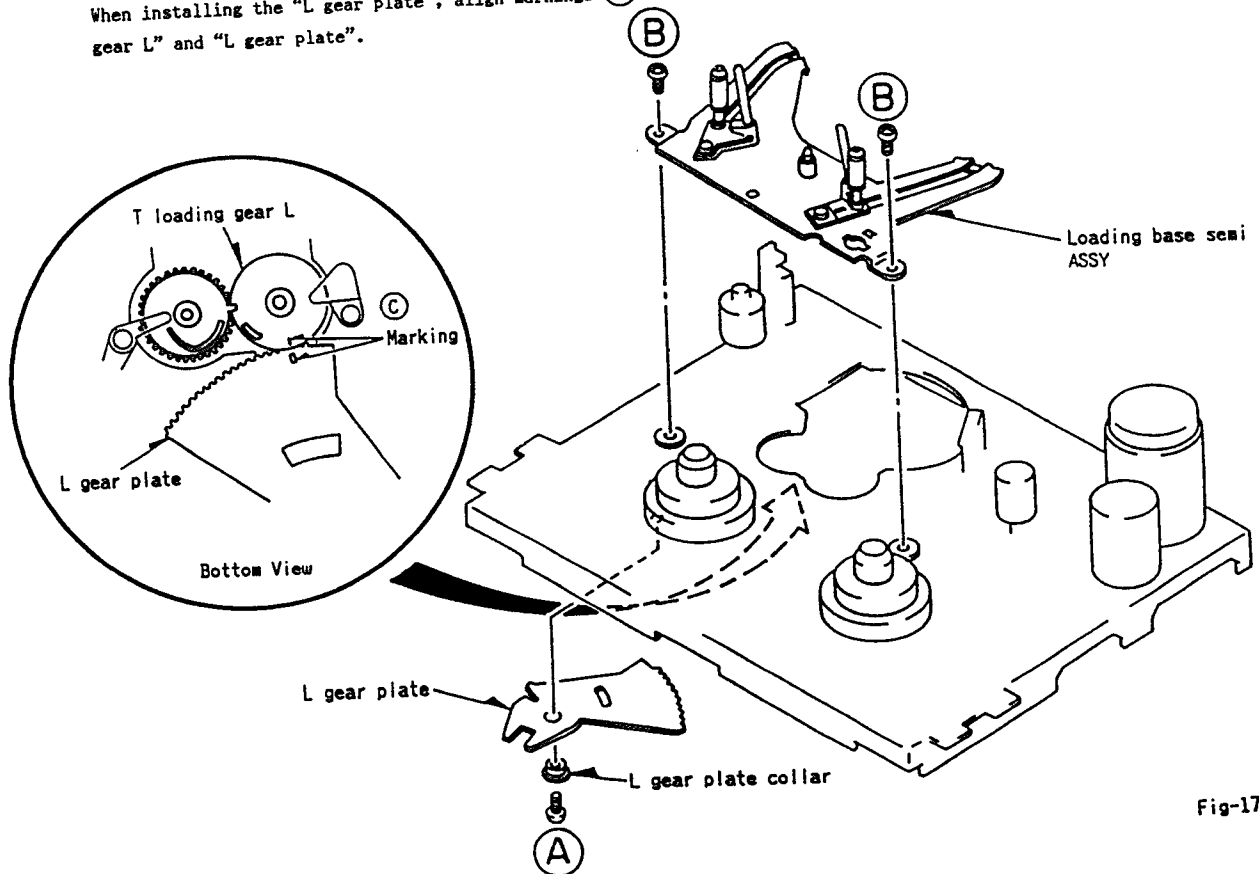

Fig-17

19. "WORMWHEEL ASSY" REMOVAL (See Figure-18)

1. Disassembly

- 1) Remove "Front loading ASSY".
- 2) Remove "Cassette load bracket ASSY".
- 3) Remove E-Ring (A).
- 4) Remove "Wormwheel ASSY". ("Wormwheel", "Friction spring", "Friction gear")

2. Assembly

- 1) Turn the "Lift gear R" fully counterclockwise.
- 2) Restore "Wormwheel ASSY" to the stud.

≡Remark≡

Match "Lift gear R" to the "Wormwheel hole" as illustrated.

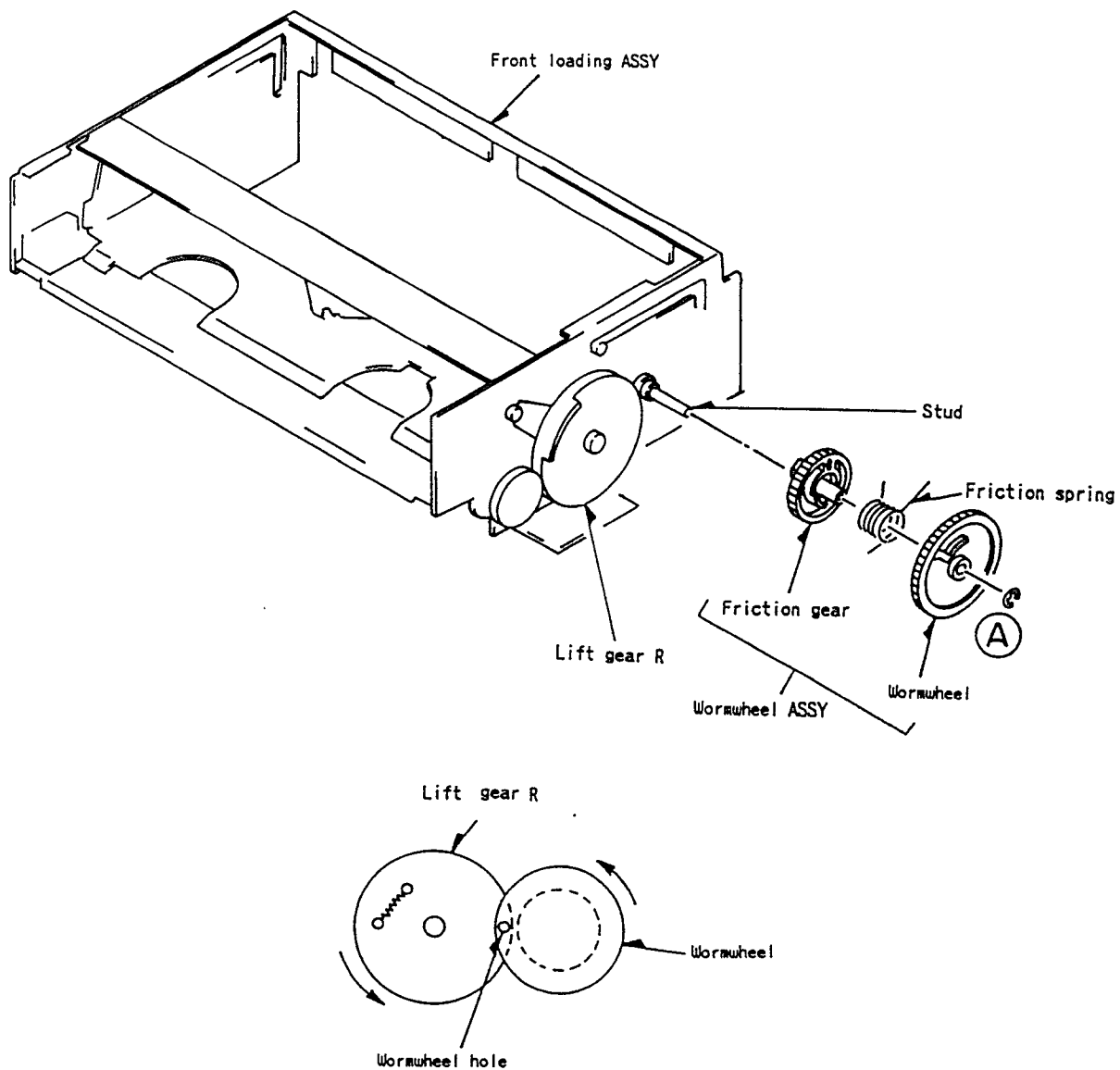

Fig-18

ELECTRICAL MAIN PARTS LIST

NOTE:

As regards the resistors and capacitors, refer to the circuit diagrams and the PCB assy drawings contained in this manual.

PWB COMBI A COMPL PARTS LIST

REF. NO.	PARTS NO.	DESCRIPTION
	*9A02816040	PWB COMBI A COMPL(PCB ASSY) (CONSISTS OF MAIN,FRONT,HEAD PCB SECTION)
	*9A02825600	PWB, COMB A (CONSISTS) (CONSISTS OF MAIN,FRONT,HEAD,CON.PCB)

PCB-A.....MAIN PCB SECTION

BT107	9A02821700	CONN ASSY, 6P ES
BT203	9A02822400	CONN ASSY, 7P AA-31
BT701	9A02822600	CONN ASSY, 2P AE-31
CN101	9A02821500	CONN, 11P TXL V
CN102	9A02821400	CONN, 12P 6383 V WHT
CN103	9A02448300	CONN, 9P 8283 V WHT
CN104	9A02821200	CONN, 6P 8283 V WHT
CN105	9A02447200	CONN, 7P HBRK 7S-2
CN108	9A02447000	CONN, 6P 1L-SDD M
CN109	9A02446700	CONN, 7P 1L-SDD F
CN201	9A02447300	CONN, 9P HBRK 9S-2
CN202	9A02447400	CONN, 11P HBRK 11S-2
CN205	9A02446900	CONN, 11P 1L-SDD F
CN207	9A02446800	CONN, 9P 1L-SDD F
CN301	9A02821300	CONN, 10P 8283 V WHT
D101-105	9A02436600	DIODE, ISS133
D201-205	9A02436600	DIODE, ISS133
D301, 302	9A02436600	DIODE, ISS133
DL401	9A02450500	DL, EFD-JF124A13F
FL331	9A02822800	FLTR, MXV-7XF 3M
FL401	9A02451600	FLTR, SFS 5.06ME
FL421	9A02822700	FLTR, AC-7 4.43M
FL431	9A02450300	FLTR, LPF 1M
IC101	9A02821800	IC, UPD75108CW-A47
IC102	9A02446300	IC, BA6209-V3
IC103	9A02454400	IC, PST 523D
IC201	9A02450100	IC, MN67481P
IC202, 203	9A02445900	IC, M5223L
IC204	9A02446200	IC, BA6219B
IC206	9A02448000	IC, TC4011BP
IC301	9A02446100	IC, LA7323
IC302	9A02446000	IC, LC8992
IC401	9A02446600	IC, LA7333
IC701	9A02438800	IC, BA7767AS
J301	9A02820900	JACK, PIN 4P YBYB
L101, 201	9A02451300	COIL, 47UH
L202, 203	9A02451500	COIL, 220UH EL0909
L301, 401	9A02451300	COIL, 47UH
L302	9A02823900	COIL, 82UH LAL02
L303	9A02439800	COIL, 180UH LAL02

Parts marked with *require longer delivery time

PWB COMBI A COMPL PARTS LIST

REF. NO.	PARTS NO.	DESCRIPTION
L351, 701	9A02440100	COIL, 100UH
L352, 353	9A02451100	COIL, 68UH LAL02
L402	9A02451200	COIL, 27UH LAL02
L403	9A02451000	COIL, 3.3UH LAL02
L404	9A02451400	COIL, 18UH J
L702	9A02445000	COIL, 18MH TL-8
Q101, 102	9A02825200	TR., DTA115ES
Q105	9A02458900	TR., 2SA1048Y
Q106, 108	9A02436700	TR., DTC144ES
Q107	9A02825000	TR., DTA114YS
Q201, 209	9A02442300	TR., 2SC1740S(RS)
Q202, 208	9A02436700	TR., DTC144ES
Q210, 301	9A02442400	TR., 2SA933S(RS)
Q211, 362	9A02436700	TR., DTC144ES
Q302, 305	9A02442400	TR., 2SA933S(RS)
Q303, 331	9A02442300	TR., 2SC1740S(RS)
Q304, 432	9A02455000	TR., DTA144ES
Q332, 351	9A02442300	TR., 2SC1740S(RS)
Q333, 361	9A02442400	TR., 2SA933S(RS)
Q371, 402	9A02442300	TR., 2SC1740S(RS)
Q372, 431	9A02442400	TR., 2SA933S(RS)
Q401, 702	9A02436700	TR., DTC144ES
Q403, 411	9A02442300	TR., 2SC1740S(RS)
Q412	9A02826300	TR., 2SC2458BL
Q433, 434	9A02442300	TR., 2SC1740S(RS)
Q701	9A02445100	TR., 2SC3940(R)
R130, 236	9A02448200	R., FUSE 1/2W 3.3
R235	9A02448100	R., FUSE 1/4W 100
RF301	9A02822900	RF MOD, 140A
SFR201	9A02824900	SFR, 220K DIA6
SFR202	9A02824900	SFR, 220K DIA6
SFR301	9A02454600	SFR, 3.3K DIA6 V
SFR302	9A02454700	SFR, 10K DIA6 V
SFR303	9A02824700	SFR, 22K DIA6 V
SFR304	9A02454700	SFR, 10K DIA6 V
SFR331	9A02454500	SFR, 1K DIA6 V
SFR351	9A02454500	SFR, 1K DIA6 V
SFR431	9A02824600	SFR, 330 DIA6 V
SFR701	9A02824800	SFR, 47K DIA6 V
SH001	9A02822100	SHLD, AU 8
SW301	9A02821100	SW, SL 2-2-3 SSU1
T701	9A02439500	COIL, OSC BIAS-70K
X101	9A02824000	CF, CST 4.19MGW
X401	9A02458800	VIB, XTAL 4.43M

PCB-B.....FRONT PCB SECTION

BT901	9A02821600	CONN ASSY, 12P FR-1
BT902	9A02822300	CONN ASSY, 9P FR-31
D901-909	9A02436600	DIODE, ISS133
D910, 916	9A02435900	LED, SLZ-981C-02
D911	9A02823600	LED, SLZ-381C-02

PWB COMBI A COMPL PARTS LIST

REF. NO.	PARTS NO.	DESCRIPTION
D912	9A02823700	LED,SLZ-481C-02
D913-915	9A02823600	LED,SLZ-381C-02
D918,919	9A02436600	DIODE,1SS133
LP901	5761597600	PIN,READ
Q902	9A02825100	TR.,DTC114ES
RB901	9A02820800	REMOCON UNIT,GPIU501
RV901	9A02821000	VOL.,250KB 09K113L6
SW901-909	9A02825300	SW,TACT EVQ-21404M
PCB-C.....HEAD PCB SECTION		
BT602	9A02822200	CONN ASSY,10P VH-31
CN601	9A02438900	CONN, 6P IL-SDD F
IC610	9A02438700	IC,LA7320
L601,602	9A02440100	COIL,100UH
L630	9A02439700	COIL, 47UH
L631	9A02439900	COIL,5.6UH LAL02
L632,642	9A02823800	COIL,3.3UH
L633	9A02439600	COIL, 15UH LAL02
L634	9A02439800	COIL,180UH LAL02
LP601	5761597600	PIN,READ
Q630-632	9A02442400	TR.,2SA933S(RS)
Q633,634	9A02442300	TR.,2SC1740S(RS)

POWER UNIT PARTS LIST

REF. NO.	PARTS NO.	DESCRIPTION
PCB-D	*9A02818240	POWER UNIT PCB ASSY
C 1	Δ 9A02428100	C.,MYLAR 0.22UF/250V
C 2-1	9A02820200	C.,CERAMIC 3300PF/250V
C 2-2	9A02820200	C.,CERAMIC 3300PF/250V
C 3	9A02428300	C.,ELEC 82UF/400V
C 4	9A02428400	C.,MYLAR 0.047UF/630V
C 5	9A02428600	C.,ELEC 1UF/400V
CN 1	9A02819800	CCT-9302-0101
D 1	9A02429900	DIODE,SIWBA60
D 2	9A02427300	DIODE,1SS202(1)-T1
D 3	9A02430000	DIODE,HZ 6.2V
D 4, 5	9A02430100	DIODE,S3LA20-04P15
D 6	9A02430300	DIODE,HZ24PB-TK
F 1	Δ 9A02430500	FUSE,1.6A 250V
HIC1	9A02430600	HIC,MA2830 F4005
IC 1	9A02430700	IC,AN1431T-TA
IC 2	9A02430800	IC,AN78M05FA
IC 3	9A02819900	IC,AN78L09F TA
J 1	Δ 9A02429800	AC JACK,CCT-9302-0101

Parts marked with *require longer delivery time

POWER UNIT PARTS LIST

REF. NO.	PARTS NO.	DESCRIPTION
L 1	Δ 9A02431000	COIL,ELF-18D290A
L 2, 3	9A02431100	COIL,RD0807A40
PC101	9A02431200	PHOTO,ON3171
Q 3	9A02427900	TR.,2SB733K3-T
Q 4	9A02819000	TR.,DTC114ES
R 4, 5	9A02820300	R.,METAL 1W 56
R 1	9A02431600	R.,METAL 3W 47K
R 2	9A02819300	R.,CARBON 1/2W 270K
R 6	Δ 9A02819100	R.,FUSE 1/4W 47
R 8	9A02432100	R.,CARBON 1/2W 240
R 9	9A02432200	R.,CARBON 100 470
R10	9A02427500	R.,METAL 1/4W 5.6K
R11	9A02820000	R.,METAL 200 270
R12	9A02427600	R.,METAL 1/4W 1.5K
R13-1	9A02819600	R.,CARBON 1/2W 1.5K
R13-2	9A02819600	R.,CARBON 1/2W 1.5K
R16	9A02819500	R.,CARBON 1/2W 1K
R21	9A02818300	R.,CARBON 3W 2.2
R22,23	9A02818900	R.,METAL 1W 82
T 1	Δ 9A02820100	TRANS,TS29K20V

OTHERS PCB COMPL PARTS LIST

REF. NO.	PARTS NO.	DESCRIPTION
PCB-E.....BASE PCB SECTION		
PCB-E	*9A02763500	BASE PCB ASSY (W/MODE SW)
CP-1	9A02509300	PHOTO(REEL) SENSOR CN1385
PCB-F.....RELAY PCB-1 SECTION		
PCB-F	*9A02763600	RELAY PCB-1 ASSY
PCB-H.....RELAY PCB-2 SECTION		
PCB-H	- - - - -	RELAY PCB-2 ASSY
CN205	9A02446900	CONN,11P IL-SDD F
CN109	9A02446700	CONN, 7P IL-SDD F
PCB-I.....RELAY PCB-3 SECTION		
PCB-I	- - - - -	RELAY PCB-3 ASSY
CN207	9A02446800	CONN, 9P IL-SDD F

OTHERS PCB COMPL PARTS LIST

REF. NO.	PARTS NO.	DESCRIPTION
<u>PCB-J.....RELAY PCB-4 SECTION</u>		
PCB-J CN601	*9A02763700 9A02447000	RELAY PCB-4 ASSY CONN, 6P 1L-SDD M
<u>PCB-K.....RELAY PCB-5 SECTION</u>		
PCB-K	- - - - -	RELAY PCB-5 ASSY
<u>PCB-G.....SWITCH PCB SECTION</u>		
PCB-G	*9A02763800	SWITCH PCB ASSY (W/SWI,2,3)
<u>PCB-N.....START SENSOR PCB SECTION</u>		
PCB-N	*9A02763900	SENSOR PCB RM ASSY
<u>PCB-M.....END SENSOR PCB SECTION</u>		
PCB-M	*9A02764000	SENSOR PCB LM ASSY
<u>PCB-O.....LED PCB SECTION</u>		
PCB-O	*9A02764100	LED PCB ASSY (W/PCB-Q)
<u>PCB-L.....ACE HEAD PCB SECTION</u>		
PCB-L	*9A02764200	ACE HEAD PCB ASSY (W/PCB-R)
<u>PCB-P.....ERASE HEAD PCB SECTION</u>		
PCB-P	*9A02764300	ERASE HEAD PCB ASSY

TRANSISTOR ILLUSTRATION

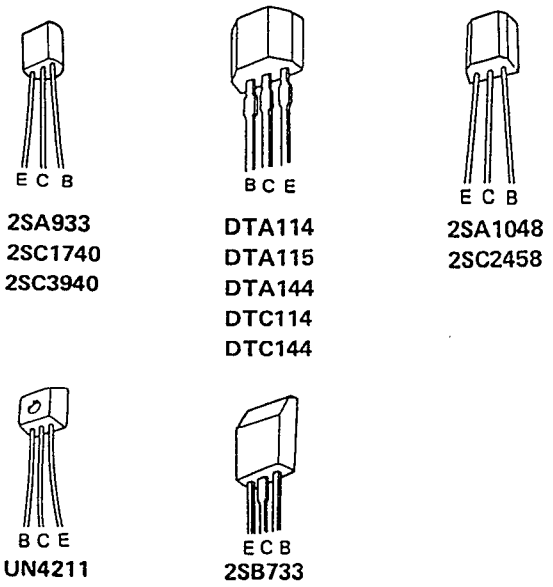

Parts marked with *require longer delivery time

B.D-1 (VIDEO SECTION)

A MAIN (Y/CHROMA SECTION) C.B

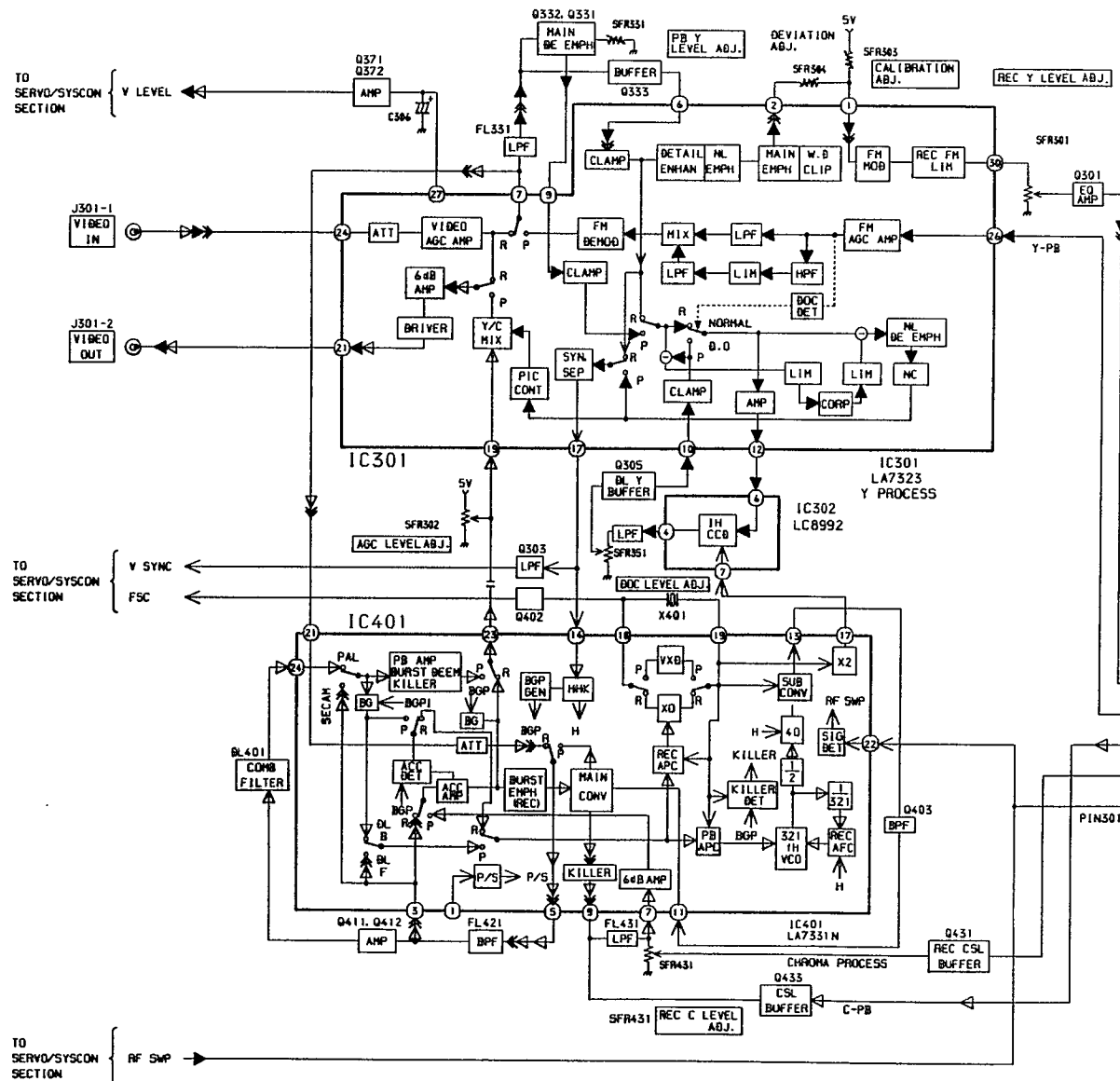

C HEAD C.B

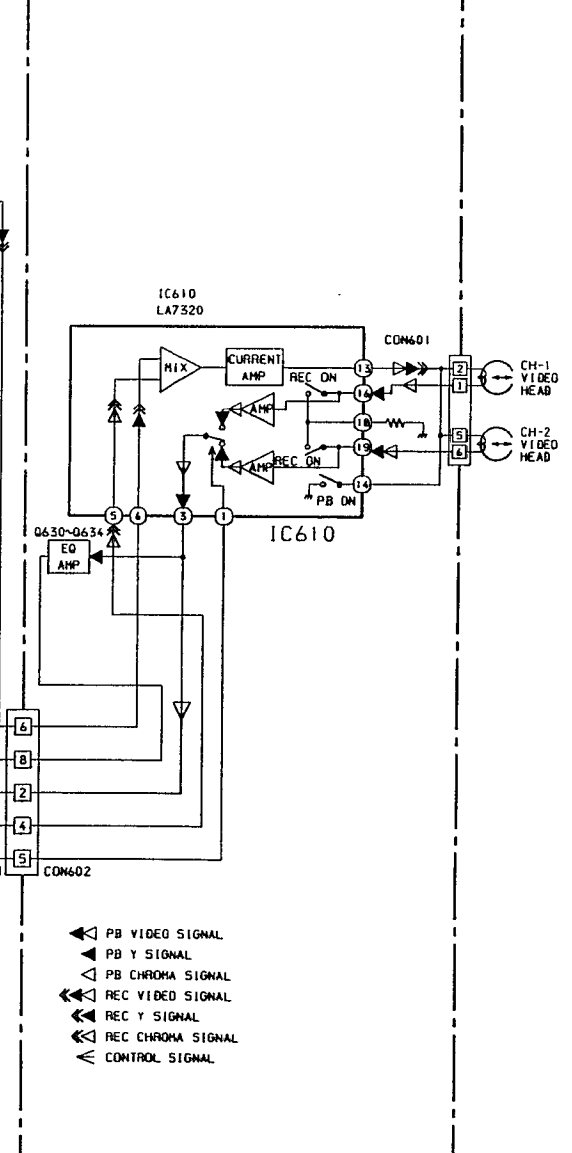

- ▶ PB VIDEO SIGNAL
- ▶ PB Y SIGNAL
- ▶ PB CHROMA SIGNAL
- ◀◀ REC VIDEO SIGNAL
- ◀◀ REC Y SIGNAL
- ◀◀ REC CHROMA SIGNAL
- ◀ CONTROL SIGNAL

BLOCK DIAGRAM - 2 (SERVO/SYSTEM CONTROL SECTION)

B.D-2 (SERVO/SYSTEM CONTROL SECTION)

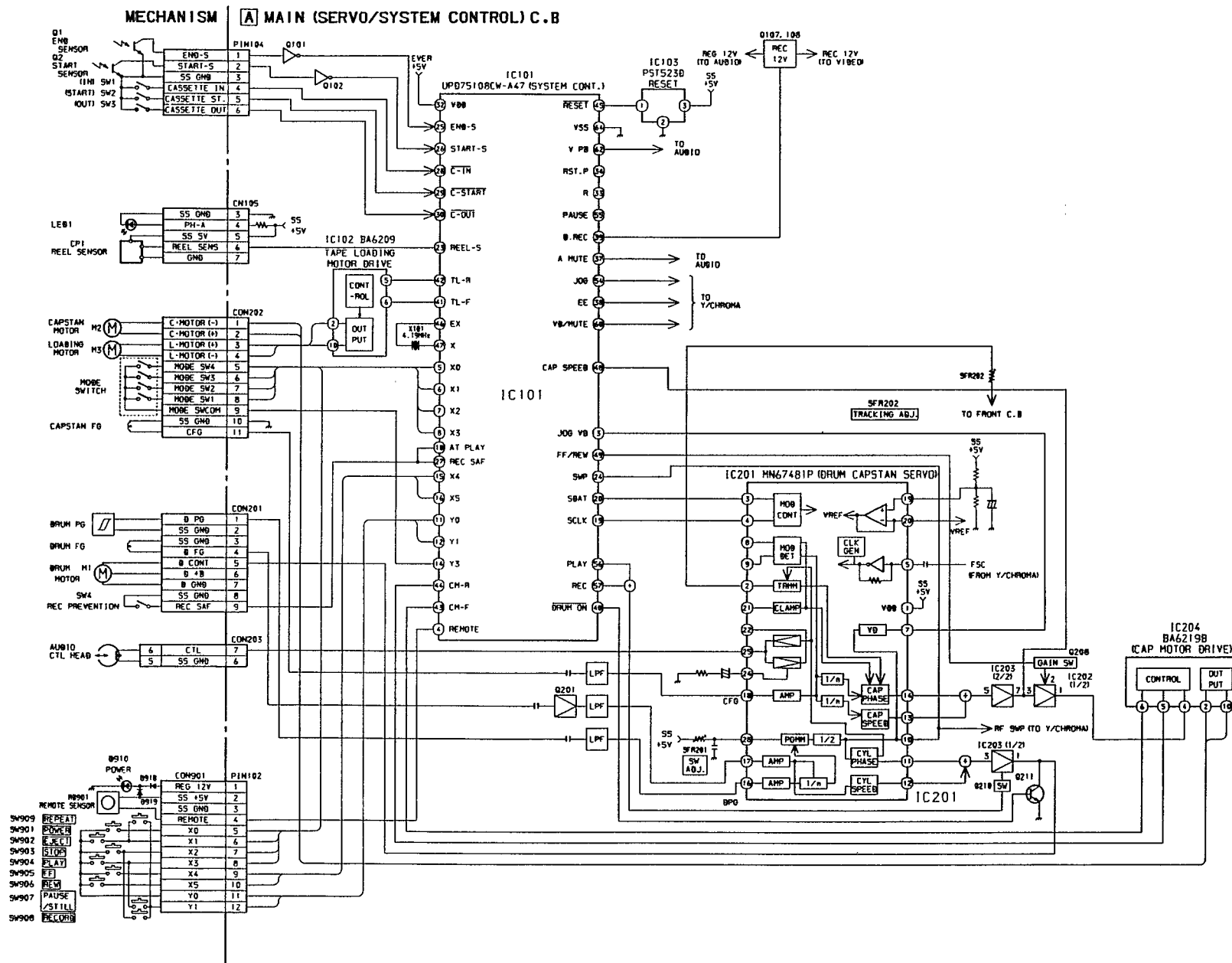

29

A MAIN (AUDIO SECTION) C.B

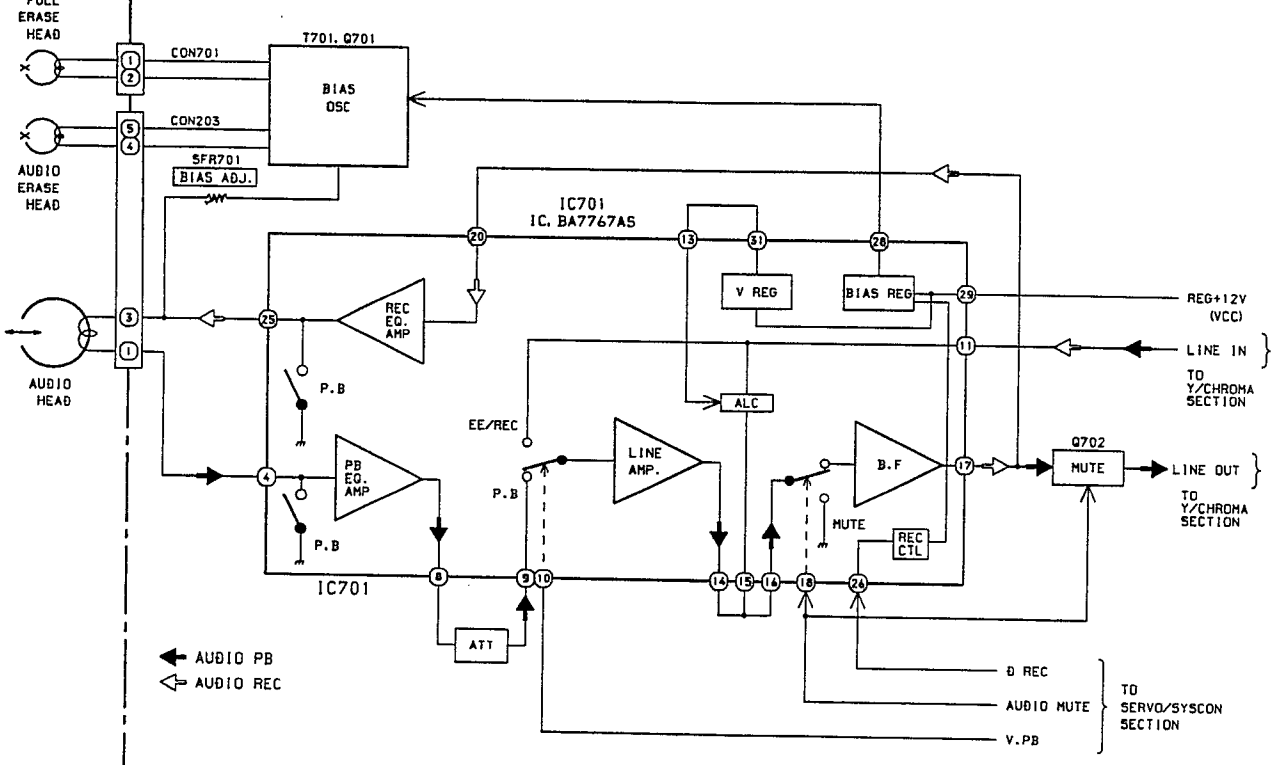

← AUDIO PB
↔ AUDIO REC

30

D POWER-UNIT C.B

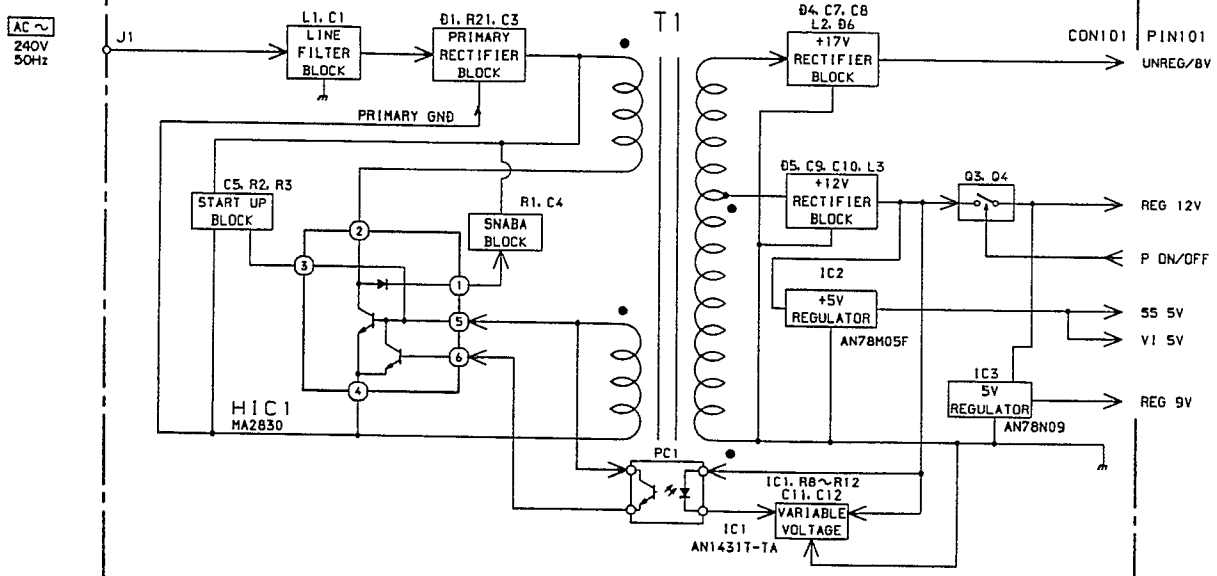

A MAIN C.B

WAVE FORM - 1 (VIDEO SECTION)

IC301 pin ⑫ (PB)
 20 μ s/div.
 500mV/div.
 LINE OUT 75 Ω TERMINATE

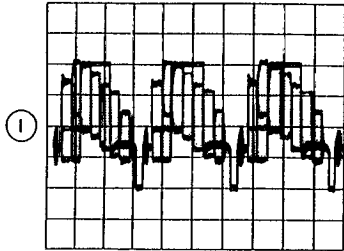

IC401 pin ⑮ (PB)
 100ns/div.
 500mV/div.

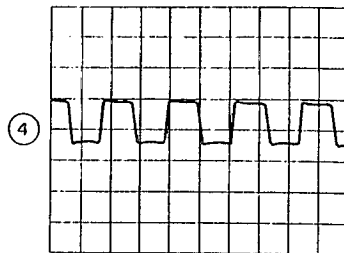

IC401 pin ③ (PB)
 20 μ s/div.
 50mV/div.

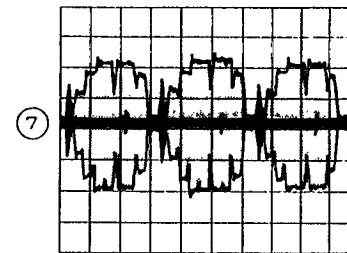

PIN301 pin ② (PB)
 5ms/div.
 100mV/div.

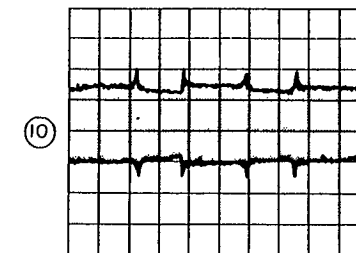

LINE OUT
 20 μ s/div.
 500mV/div.
 LINE OUT 75 Ω TERMINATE

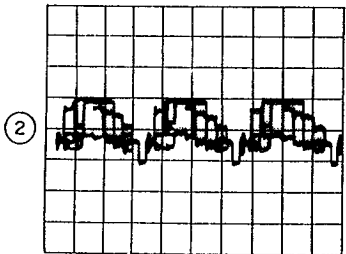

IC401 pin ⑰ (PB)
 100ns/div.
 500mV/div.

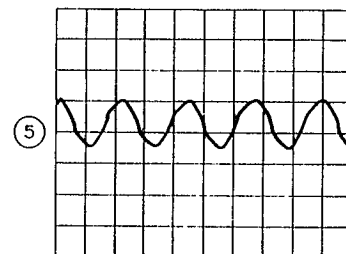

IC401 pin ⑳ (PB)
 20 μ s/div.
 50mV/div.

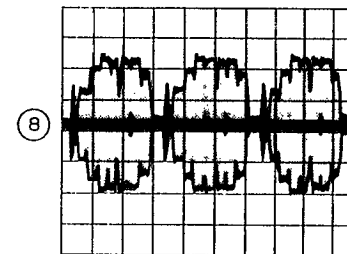

IC401 pin ⑦ (PB)
 20 μ s/div.
 100mV/div.

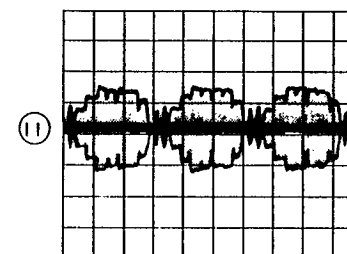

IC301 pin ⑰ (PB)
 20 μ s/div.
 100mV/div.

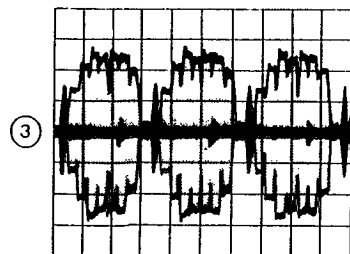

IC401 pin ⑤ (PB)
 20 μ s/div.
 500mV/div.

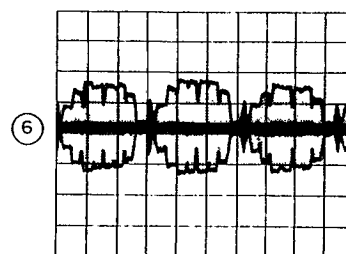

IC301 pin ⑨ (PB)
 20 μ s/div.
 100mV/div.

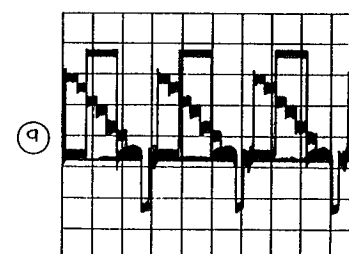

PIN301 pin ⑧ (PB)
 5ms/div.
 200mV/div.

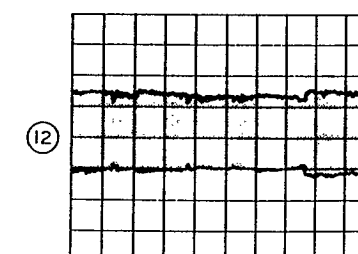

IC301 pin ⑦ (PB)
20 μ s/div.
500mV/div.

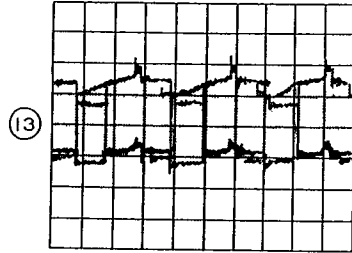

LINE OUT (EE)
20 μ s/div.
500mV/div.

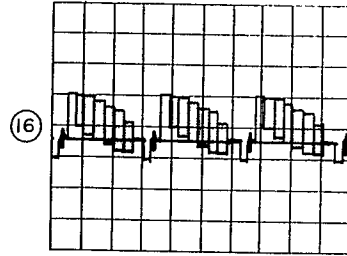

IC401 pin ⑪
100ns/div.
100mV/div.

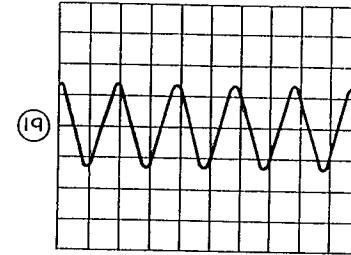

IC401 pin ⑱ (EE)
50mV/div.
100ns/div.

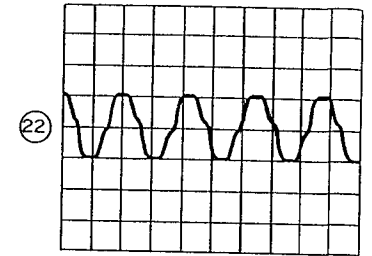

FL331 OUT (PB)
20 μ s/div.
100mV/div.

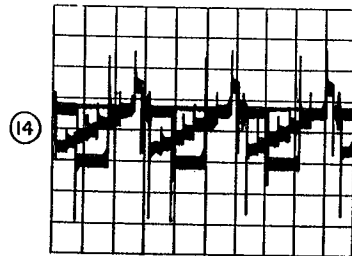

IC401 pin ⑲ (EE)
100ns/div.
500mV/div.

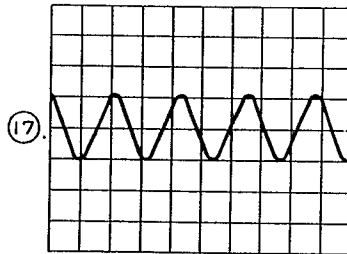

IC401 pin ⑨ (EE)
200mV/div.
20 μ s/div.

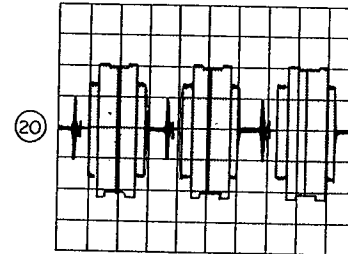

PIN301 pin ⑥ (EE)
100mV/div.
20 μ s/div.

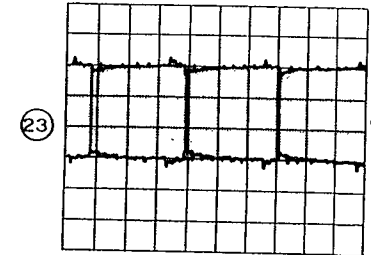

IC301 pin ⑳ (EE)
20ns/div.
500mV/div.

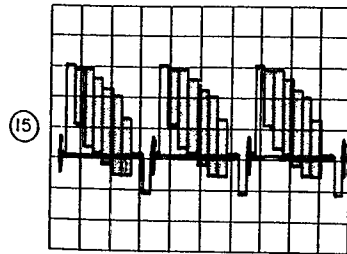

IC401 pin ⑬
100ns/div.
100mV/div.

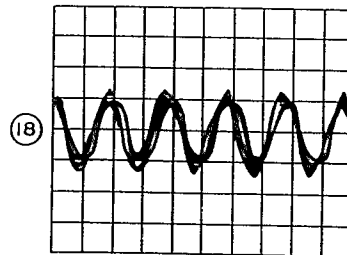

PIN301 pin ④ (EE)
50mV/div.
20 μ s/div.

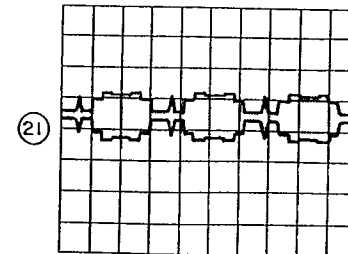

IC401 pin ⑤ (EE)
100mV/div.
20 μ s/div.

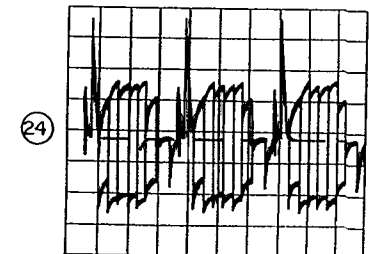

IC401 pin ③ (EE)
50mV/div.
20μs/div.

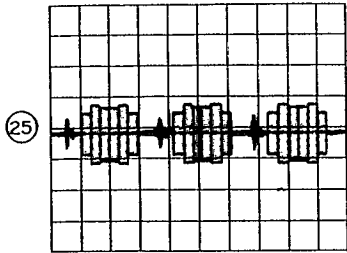

IC301 pin ⑩ (EE)
200ns/div.
500mV/div.

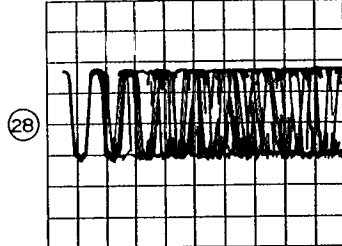

LINE IN (EE)
20μs/div.
200mV/div.

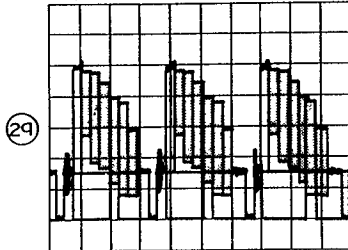

IC301 pin ⑥ (EE)
20μs/div.
100mV/div.

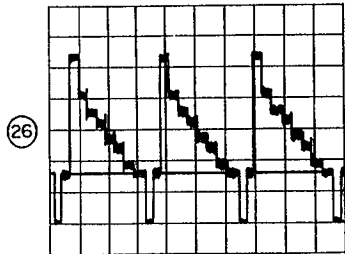

IC301 pin ⑫ (EE)
20μs/div.
200mV/div.



IC301 pin ② (EE)
20μs/div.
200mV/div.

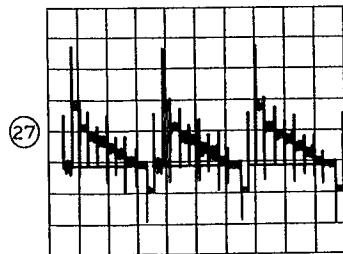

IC301 pin ⑦ (EE)
20μs/div.
200mV/div.

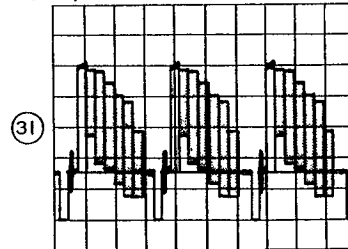

IC BLOCK DIAGRAM

IC,BA6209

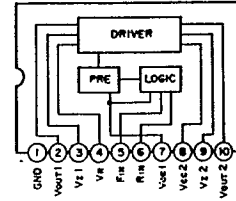

IC,BA6219B

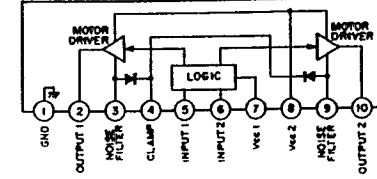

IC,MN67481

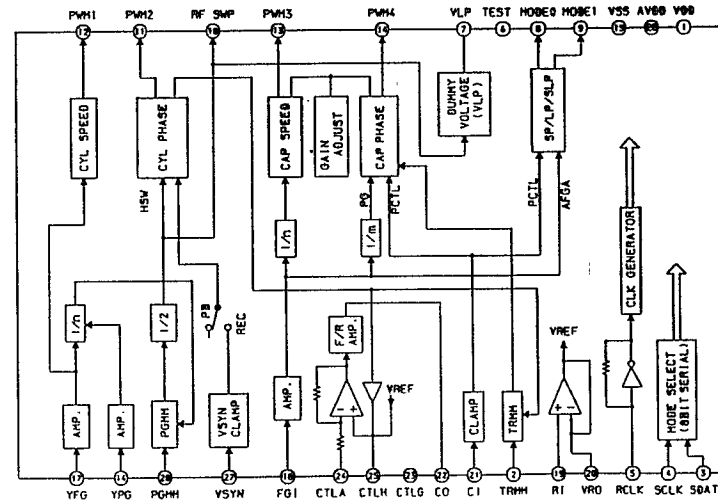

IC,LC8992

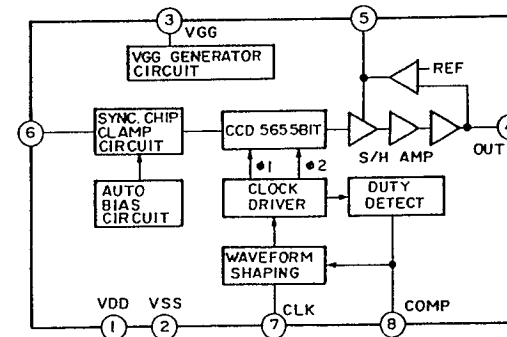

WIRE HARNESS DIAGRAM

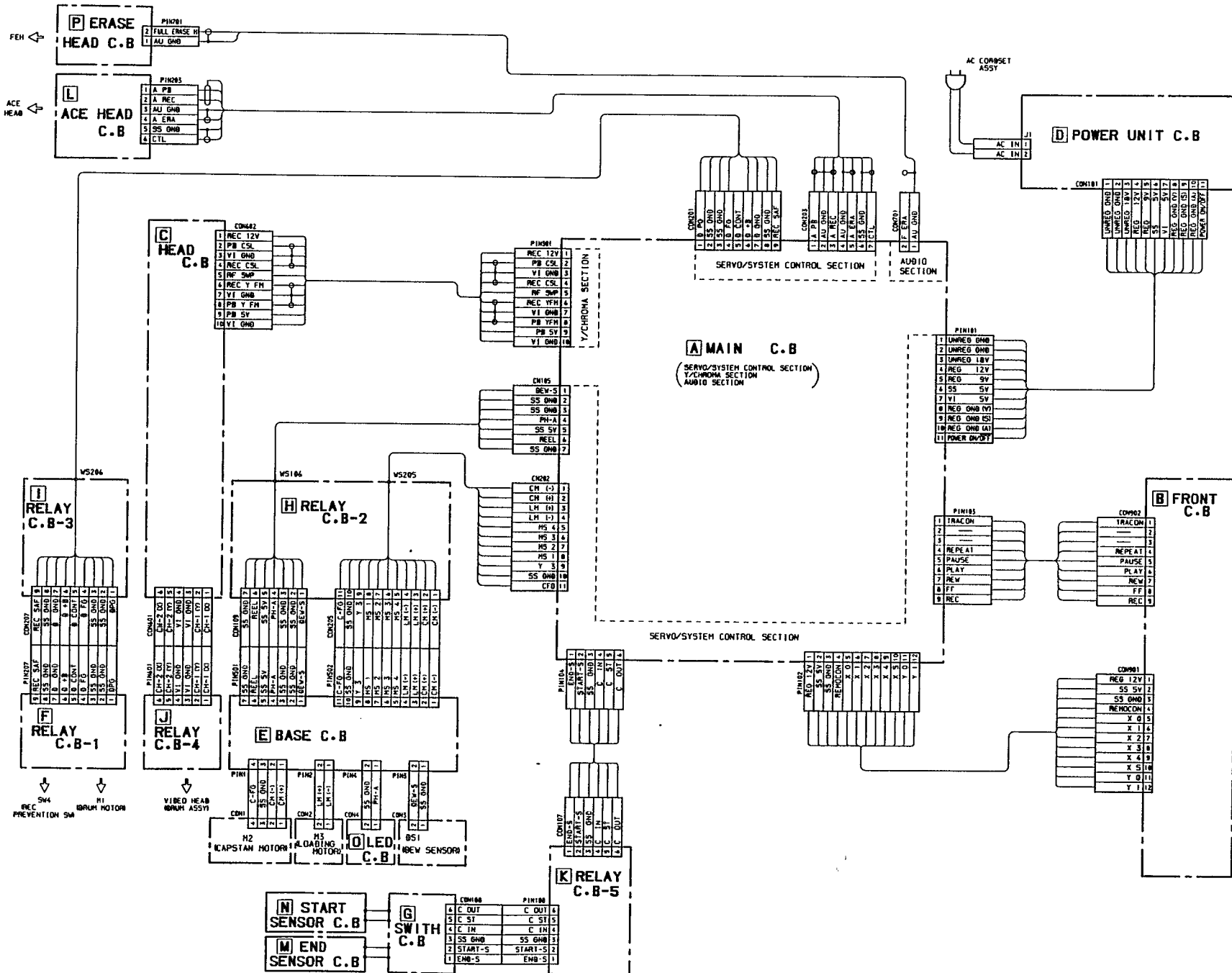

WIRING - 1 (VIDEO/AUDIO/SERVO/SYSCON SECTION)

1 2 3 4 5 6 7 8 9 10 11 12 13 14 15

A
B
C
D
E
F
G
H
I
J
K

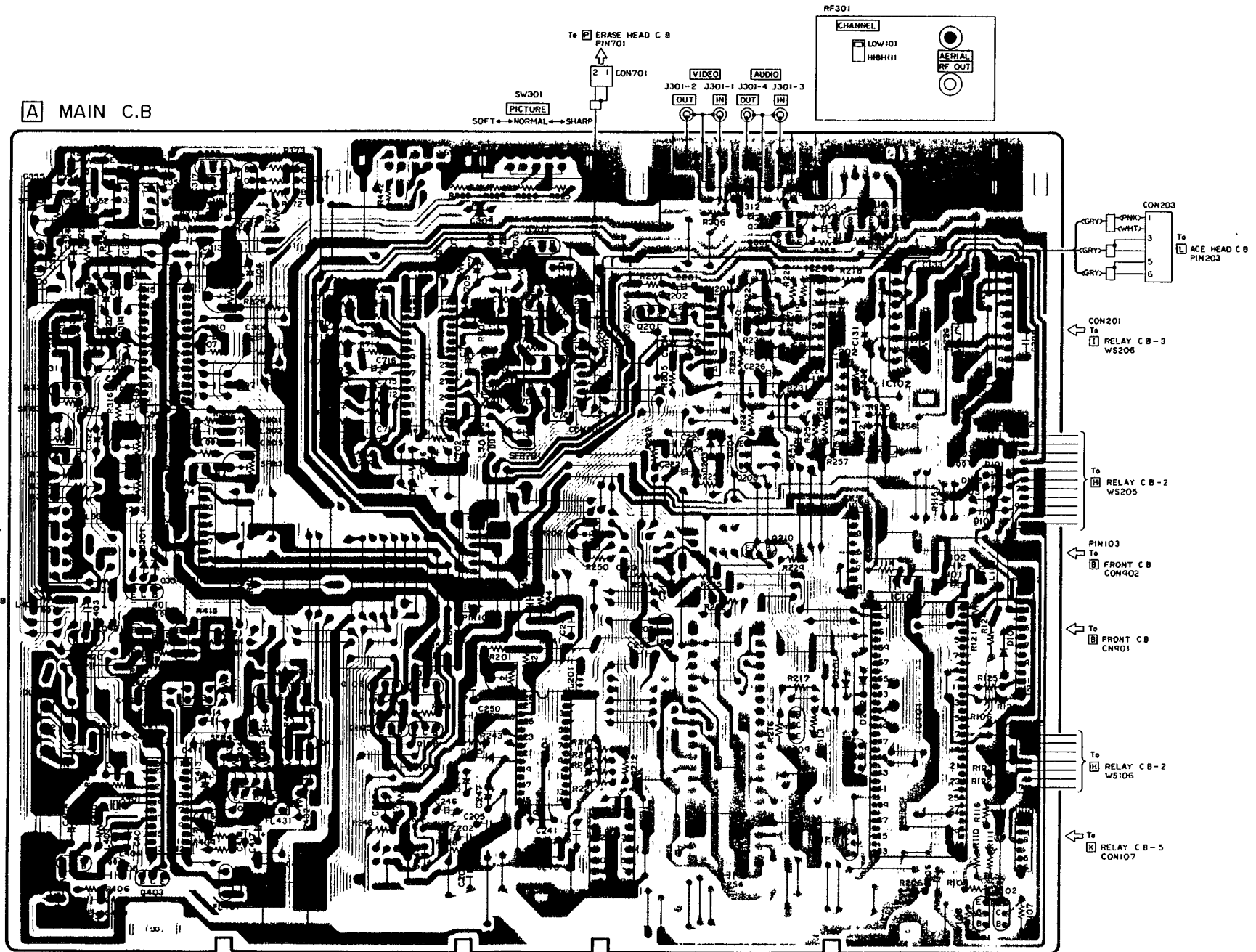

MEMO

SCHMATIC DIAGRAM – 3 (FRONT SECTION)

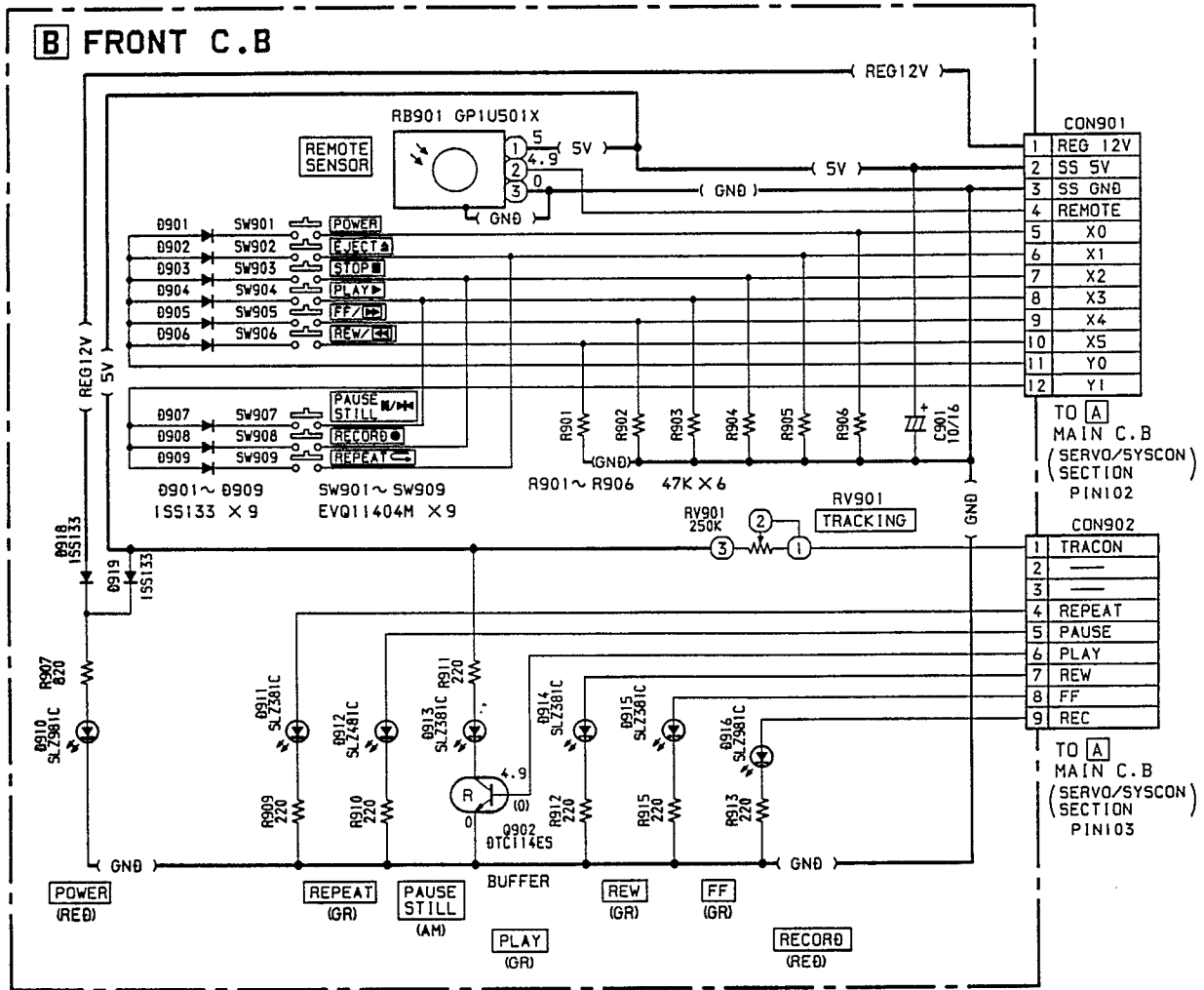

SCHEMATIC DIAGRAM - 4 (AUDIO SECTION)

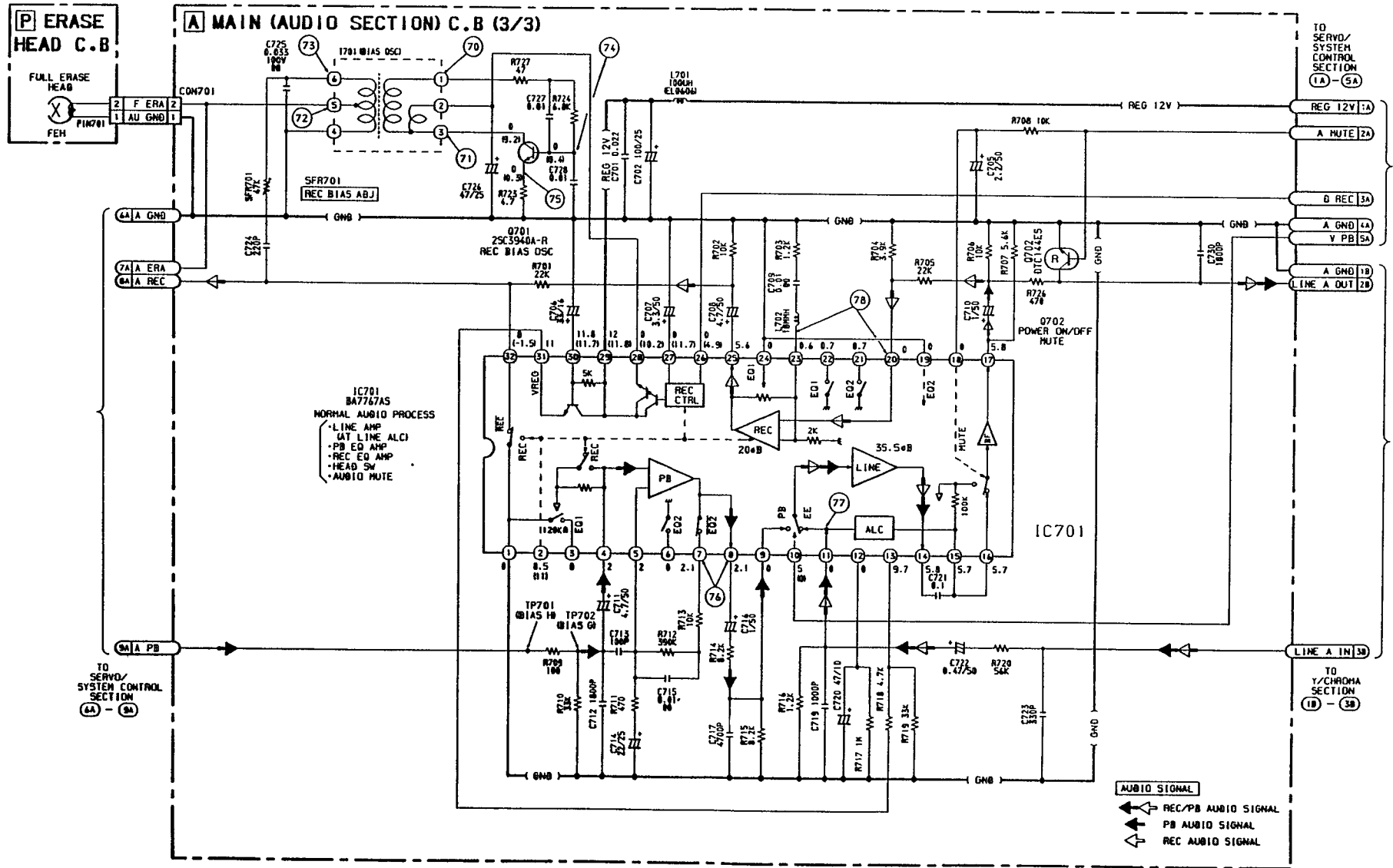

SCHEMATIC DIAGRAM - 5 (HEAD AMP SECTION)

J RELAY C.B-4

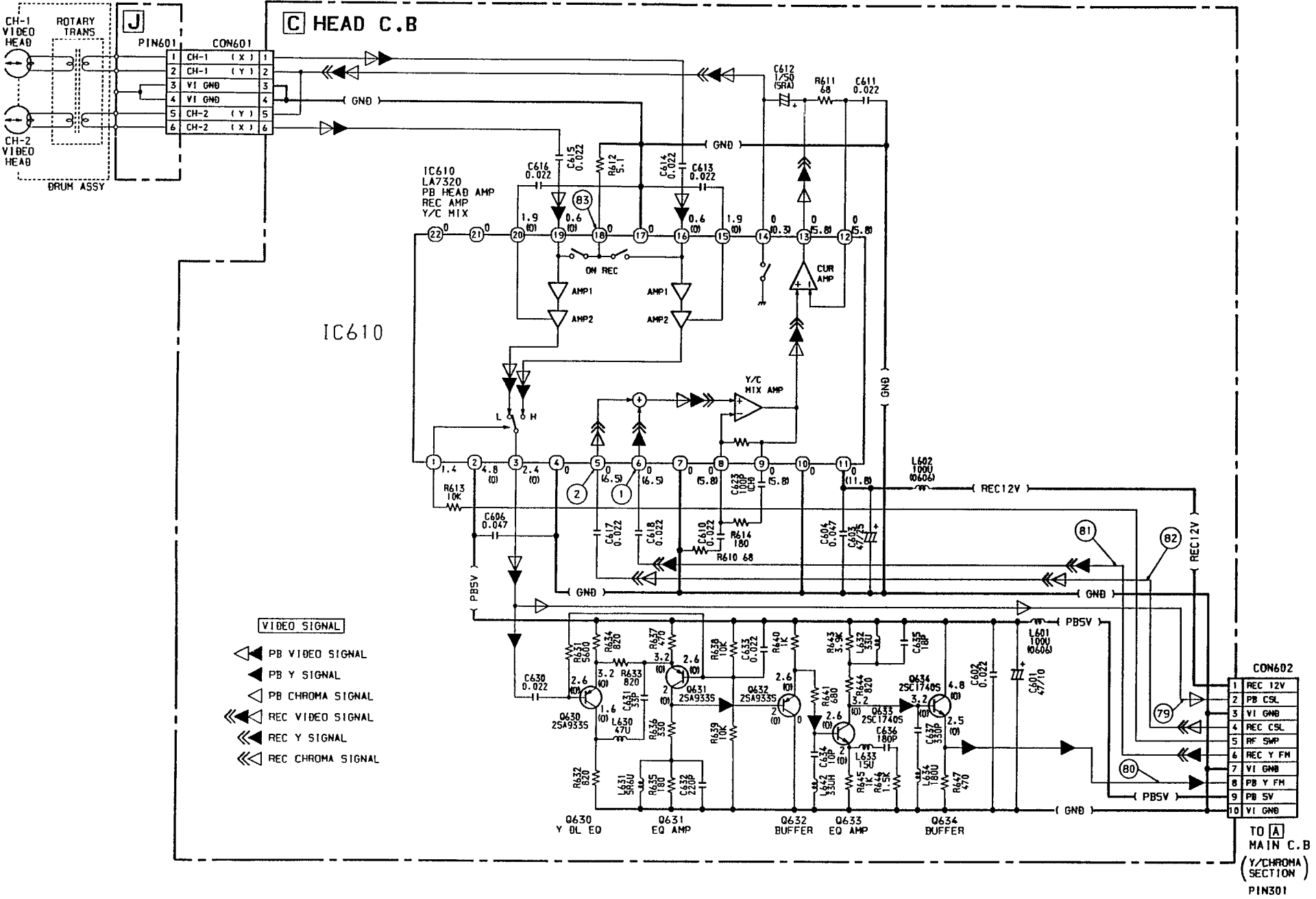

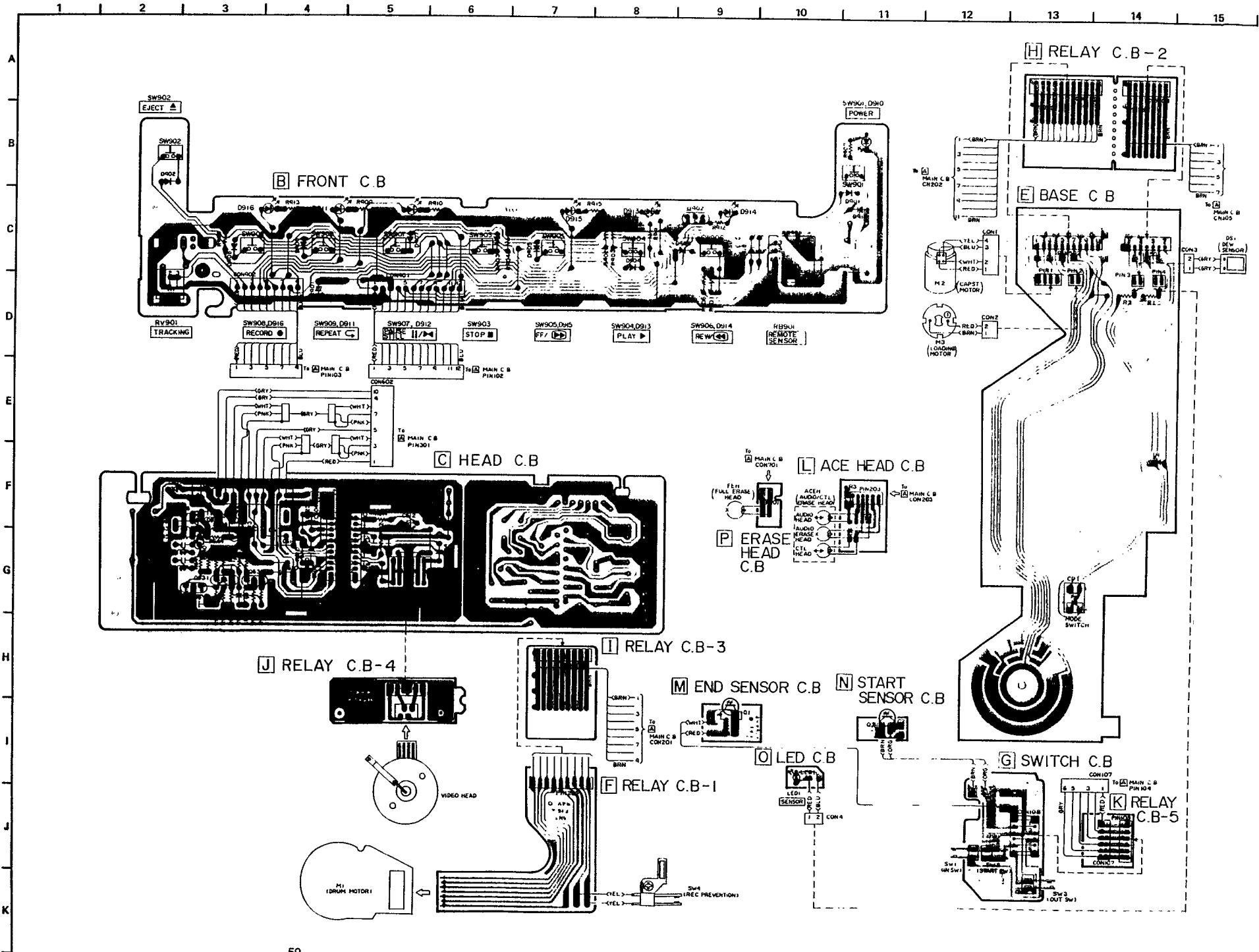

SCHEMATIC DIAGRAM - 6 (POWER - UNIT SECTION) WIRING - 3 (POWER - UNIT SECTION)

1 | 2 | 3 | 4 | 5 | 6 | 7 | 8 | 9 | 10 | 11 | 12 | 13 | 14 | 15

A

B

C

D

E

F

G

H

I

J

K

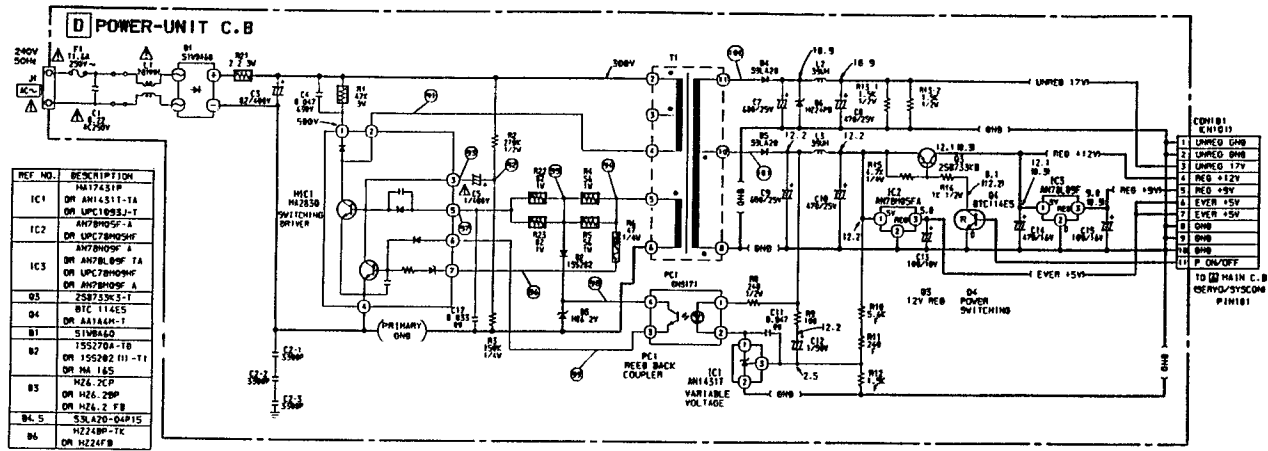

D POWER-UNIT C.B

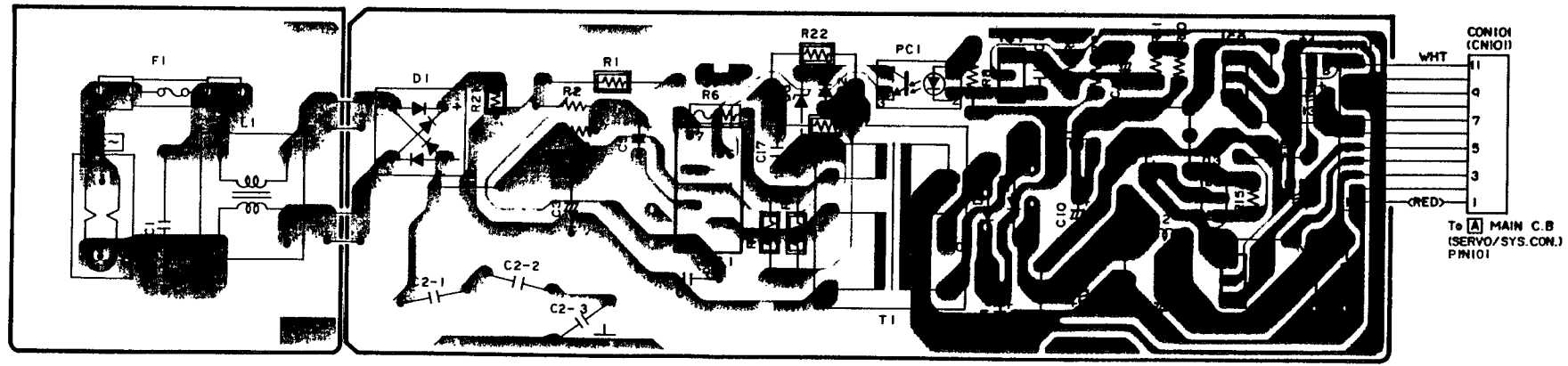

WAVE FORM - 4 (POWER - UNIT SECTION)

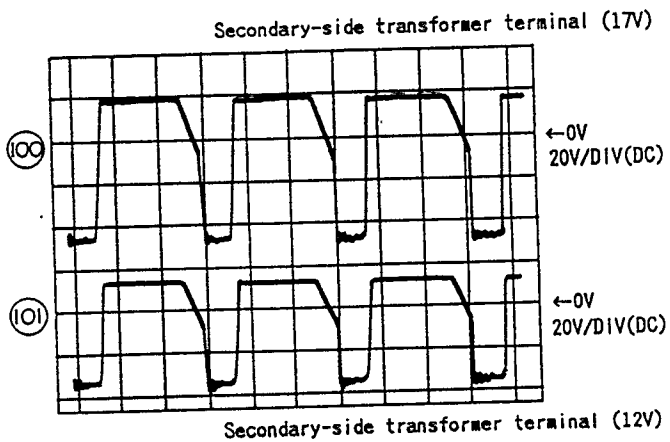
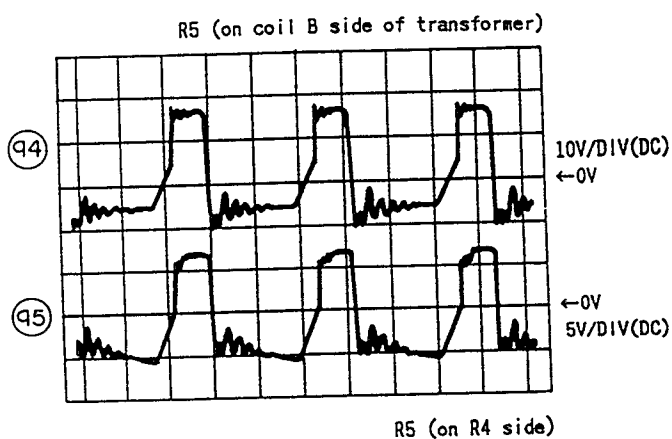
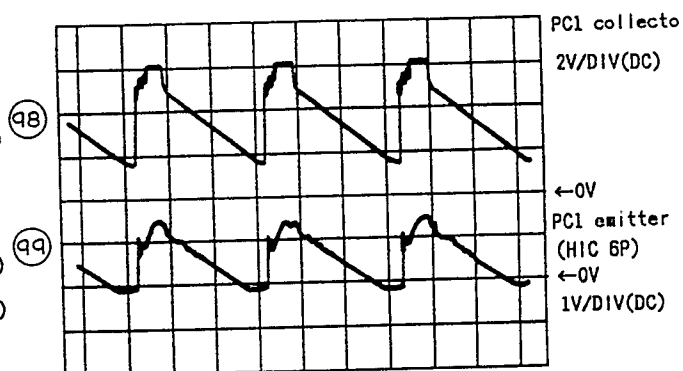
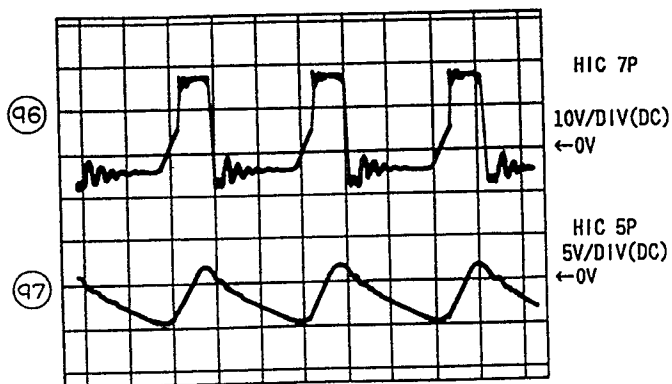
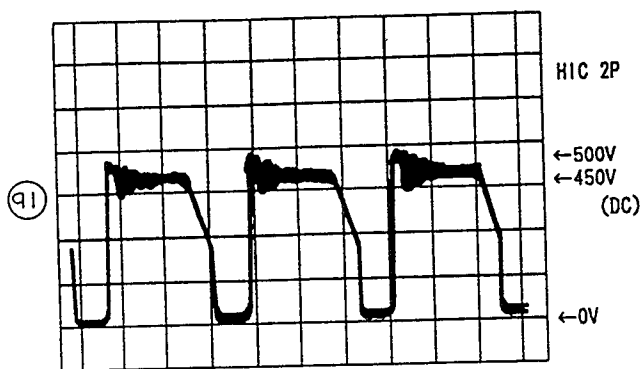

- ※ • When checking waveforms (91) - (99), connect the negative (-) terminal of C3 to ground (GND on primary side).
- When checking waveforms (100) and (101), connect pin 2 of CON101 to ground (GND on secondary side).
- Waveforms should be measured in the PB mode and with AC 220V power input.

IC DESCRIPTION

IC, μ PD75108CW-A47 (IC101)

Pin No.	Pin Name	I/O	Description
1	TEST	I	Used during production. (Fixed at "H")
2	—	—	(Fixed at "H")
3	JOG VD	—	JOG VD pulse input during PUASE/CUE/REV.
4	REMOTE	I	Receives a control signal from the light receiving block.
5	X0	I	Matrix input.
6	X1	I	Matrix input.
7	X2	I	Matrix input.
8	X3	I	Matrix input.
9	DEW SEL	I	(Fixed at "L")
10	AUTO PLAY	I	Selects AUTO PLAY or not.
11	Y0	O	Matrix output.
12	Y1	O	Matrix output.
13	Y2	O	Matrix output.
14	Y3	O	Matrix output.
15	X4	I	Matrix input.
16	X5	I	Matrix input.
17	X6	I	Matrix input. (Fixed at "L")
18	—	—	(Fixed at "L")
19	SCLK	O	Transfers a clock signal to the servo IC.
20	SDAT	O	Transfers data to the servo IC.
21	—	—	(NC)
22	—	—	(NC)
23	REEL SNS	I	Receives a reel rotation pulse to detect abnormal stopping of the reel axis.
24	SWP	I	Receives an RF SWP pulse from the servo IC to detect abnormal stopping of the drum.
25	END	I	Tape end detection input.
26	START	I	Tape start detection input.
27	REC SAFETY	I	REC SAFETY detection input.
28	C IN	I	Cassette loading detection input.
29	C START	I	Cassette insertion detection input.
30	C OUT	I	Cassette ejection (ejection complete) detection input.
31	VPP	—	(Fixed to +5V power supply)
32	VDD	—	IC power supply (+5V).
33	C+R	O	Outputs "H" during CUE/REVIEW.
34	RSTP	O	Outputs a reset pulse to the tracking microprocessor.
35	A MUTE1/EE	—	Mutes the audio output. Muting is released when play starts. (NC)
36	—	—	(NC)
37	A MUTE	O	Mutes the audio output. "H" during MUTE.
38	EE	O	Mutes the video output. Muting is released when play starts.
39	D REC	O	Outputs "H" when the operation becomes stable after STOP is switched to REC or REC PAUSE is switched to REC.
40	DRUM ON	O	Drum rotation on/off control.
41	TL-F	O	Tape loading motor forward rotation control.
42	TL-R	O	Tape loading motor reverse rotation control.
43	CM-F	O	Capstan motor forward rotation control.
44	CM-R	O	Capstan motor reverse rotation control.
45	RESET	—	Hard reset.
46	EX	—	Connected to the clock generator.
47	X	—	Connected to the clock generator.

Pin No.	Pin Name	I/O	Description
48	CAP. SPEED	O	Stabilizes the speed when CUE/REVIEW is returned to PLAY.
49	FF/REW	O	Raises the gain of the capstan error amplifier during FF/REW.
50	D0	O	} Output the 4-bit data according to the sensor input in the test mode.
51	D1	O	
52	D2	O	
53	D3	O	
54	JOG	O	Outputs "H" in the CUE/REV/PB PAUSE mode.
55	PAUSE	O	Outputs "H" in the PB PAUSE/REC PAUSE mode.
56	PLAY	O	Outputs "H" in the PLAY mode.
57	REC	O	Outputs "H" in the REC/REC PAUSE mode.
58	REW	O	Outputs "H" in the REW mode.
59	FF	O	Outputs "H" in the FF mode.
60	VD·MUTE	O	Mutes the video output during power off.
61	REPEAT	O	Outputs "H" in the REPEAT mode.
62	V PB	O	Outputs "H" when the tape transport is stabilized during PLAY.
63	POWER	O	Power unit on/off control. Outputs "H" when the power unit is turned on.
64	VSS	-	GND of power supply.

IC, MN67481P (IC201)

Pin No.	Pin Name	I/O	Description												
1	VDD	-	Power supply (+5V) of digital section.												
2	TR MM	I	Tracking monostable multivibrator. Delay time constant for CTL locking position adjustment.												
3	SDAT	I	Servo mode setting data input.												
4	SCLK	I	Servo mode setting clock input.												
5	RCLK	I	Reference timing clock for servo control (PAL : 4.433618MHz).												
6	TEST	I	Unused (fixed at "L").												
7	VLP	O	Artificial VD output (only during CUE, REV and STILL).												
8	MOD 0	O	} Record mode output.												
9	MOD 1	O													
			<table border="1"> <thead> <tr> <th></th> <th>MODE 0</th> <th>MODE 1</th> </tr> </thead> <tbody> <tr> <td>SP mode 3H</td> <td>"L"</td> <td>"L"</td> </tr> <tr> <td>LP mode 3H</td> <td>"H"</td> <td>"L"</td> </tr> <tr> <td>EP mode 6H</td> <td>"H"</td> <td>"H"</td> </tr> </tbody> </table>		MODE 0	MODE 1	SP mode 3H	"L"	"L"	LP mode 3H	"H"	"L"	EP mode 6H	"H"	"H"
	MODE 0	MODE 1													
SP mode 3H	"L"	"L"													
LP mode 3H	"H"	"L"													
EP mode 6H	"H"	"H"													
10	RF SW P	O	RF SW P output (PAL : 25Hz).												
11	PWM 2	O	Drum servo phase error output.												
12	PWM 1	O	Drum servo speed error output.												
13	PWM 3	O	Capstan servo speed error output.												
14	PWM 4	O	Capstan servo phase error output.												
15	VSS	-	Power supply (GND) of digital section.												
16	YPG	I	Drum PG amplifier input.												
17	YFG	I	Drum FG amplifier input.												
18	FGI	I	Capstan FG amplifier input.												
19	RI	I	Sets the reference neutral point voltage (+2.5V) of the internal linear amplifier.												
20	VRO	O	Reference voltage (set by pin 19) output.												
21	CI	I	CTL clamp input.												
22	CO	O	CTL amplifier output.												
23	CTLG	-	CTL amplifier GND.												
24	CTLA	I	Sets the CTL amplifier gain (negative input terminal).												
25	CTLH	I	CTL input.												
26	A VDD	-	Power supply (+5V) of analog section.												
27	V SYN	I	Vertical sync signal input.												
28	PG MM	I	Switching position monostable multivibrator. Delay time constant for head switching point adjustment.												

PRACTICAL SERVICE FIGURE

Output level

Video (Impedance) : $1.0 \pm 0.2V_p - p$ ($75 \Omega \pm 20\%$,
Unbalance)
Audio (Impedance) : $-8 \pm 3dB$ (Less than $2.2k\Omega$)
RF Modulated (Impedance) : $74 \pm 3dB \mu V$ (75Ω ,
Unbalance)
46.25MHz (0 CH) ~57.25MHz (1 CH)

Input Level

Video (Impedance) : $1.0 \pm 0.5V_p - p$ ($75 \Omega \pm 20\%$,
Unbalance)
Audio (Impedance) : $-10 \pm 3dB$ s (More than
 $47k\Omega$)

S/N Ratio

Video (SP mode) : More than 42dB (PB)
(Y - Signal)
More than 40dB (R/P)
(Y - Signal)
More than 38dB (PB)
(C - Signal,AM)
More than 38dB (R/P)
(C - Signal,AM)
More than 36dB (PB)
(C - Signal,PM)
More than 36dB (R/P)
(C - Signal,PM)

Audio (SP mode) : More than 40dB (R/P)

Audio Distortion : Less than 3% (R/P)

Audio Frequency Response : 200Hz~6kHz $\pm 4dB$
(SP mode)

Horizontal Resolution : More than 230 lines
(PB,R/P)

Erase Ratio : More than 55dB

Bias Frequency : 70kHz $\pm 10\%$

Tape Speed (SP mode) : 23.39mm/sec $\pm 0.5\%$

Wow & Flutter : Less than 0.5%
(R/P,DIN UNWTD)

F.F time : Less than 300sec (T - 120)

REW time : Less than 300sec (T - 120)

Back tension : $46.5 \pm 12g - cm$

Loading time : Less than 3sec

Unloading time : Less than 3.5sec

Test Tape : MVP - 08 (PB)
MVP - 09 (PB)
TPV - 160S
TTV - 06T
TTV - P5
HS - T120

ELECTRICAL ADJUSTMENT

Preparation for adjustment

Input signal (100% white)

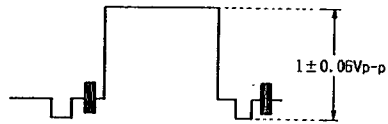

※Note : Voltage measured with a signal generator connected to the VCR

Input signal (color bar)

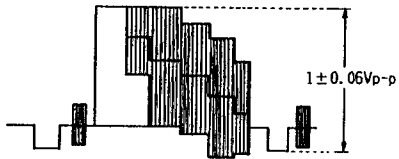

※Note : Voltage measured with a signal generator connected to the VCR

Connections of test equipment

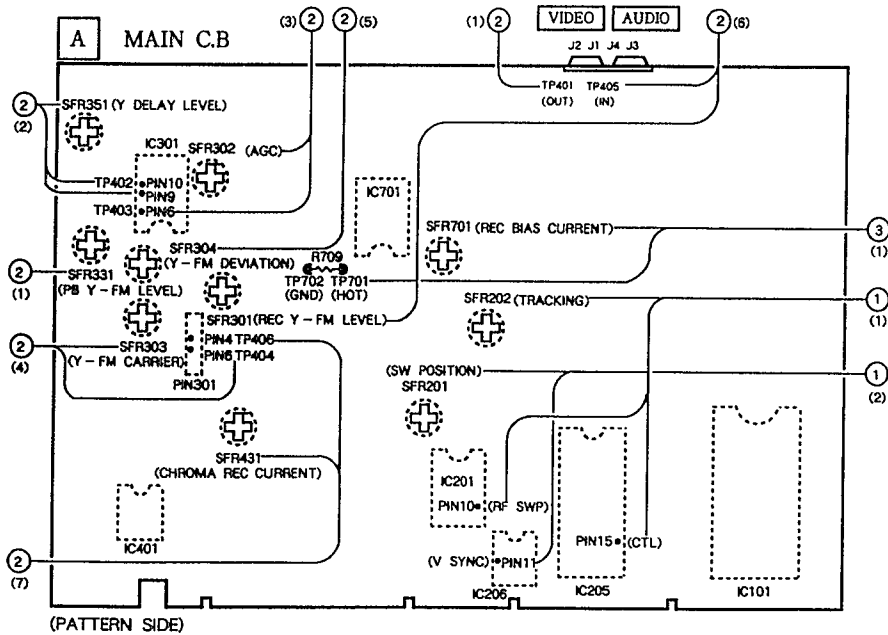
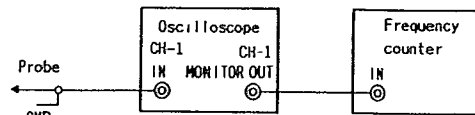

1. Servo Circuit Adjustment

(1) Tracking Adjustment ([A] MAIN C.B.)

Oscilloscope CH-1 : IC201 pin ⑩ (RF SWP)
CH-2 : IC205 pin ⑮ (CTL)

- 1) Set the VCR to the manual tracking mode.
- 2) Set RV901 (tracking VR) to the center position.
- 3) Play alignment tape ITV-P1.
- 4) Adjust SFR202 so that the position of the CTL signal is as shown in the figure below.

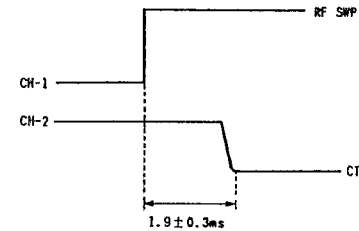

2. Video Circuit Adjustment

(1) PB Y-FM Level Adjustment ([A] MAIN C.B.)

Oscilloscope : VIDEO OUT (TP401)

- 1) Play alignment tape ITV-P1.
- 2) Adjust SFR331 so that the white 100% level is as shown in the figure below.

※Terminate the VIDEO OUT jack with 75ohms or connect a monitor to it.

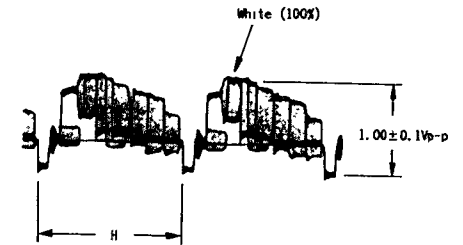

(2) Y Delay Level Adjustment ([A] MAIN C.B.)

Oscilloscope : IC301 pin ⑩ (TP402)

- 1) Play alignment tape ITV-P1.
- 2) Adjust SFR351 so that the level at pin ⑩ of IC301 is the same as that of the waveform at pin ⑨ of IC301.

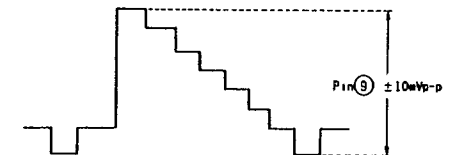

(2) Switching Position Adjustment ([A] MAIN C.B.)

Oscilloscope CH-1 : IC201 pin ⑩ (RF SWP)

CH-2 : IC206 pin ⑮ (V SYNC)

- 1) Set the VCR to the manual tracking mode.
- 2) Set RV901 (tracking VR) to the center position.
- 3) Play alignment tape ITV-P1.
- 4) Adjust SFR201 so that the V. SYNC signal is as shown in the figure below.

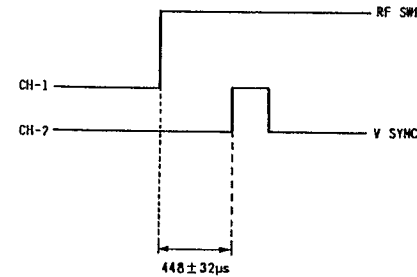

(3) AGC Adjustment ([A] MAIN C.B.)

Oscilloscope : IC301 pin ⑥ (TP403)

- 1) Switch the input selector to LINE.
- 2) Apply a 100% white signal to the VIDEO IN jack.
- 3) Adjust SFR302 so that the Y signal is as shown in the figure below in the E-E mode.

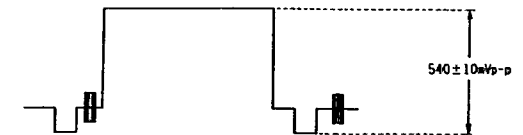

- (4) Y-FM Carrier Frequency Adjustment ([A] MAIN C.B)
 Oscilloscope : PIN301 pin ⑥ (TP404)
 1) Switch the input selector to LINE.
 2) Set the VCR to the no signal input state (with no input connected to the VIDEO IN jack).
 3) Set the VCR to the E-E mode.
 4) Adjust SFR303 so that the frequency counter reads $3.0MHz \pm 0.05MHz$.

- (5) Y-FM Deviation Adjustment ([A] MAIN C.B)
 ※The Y-FM carrier frequency adjustment should have been completed.
 Oscilloscope : VIDEO OUT (TP401)
 1) Switch the input selector to LINE.
 2) Record a 100% white signal.
 3) Play the recorded section and check the Y signal level.
 4) If out of specification turn SFR304.
 5) Repeat 2)~4) until observe the waveform as indicated below.
 ※Terminate the VIDEO OUT jack with 75ohms or connect a monitor to it.

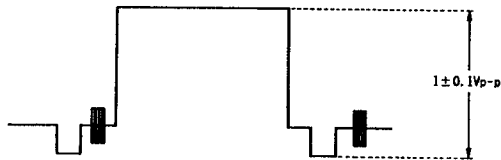

- (6) REC Y-FM Level Adjustment ([A] MAIN C.B)
 Oscilloscope CH-1 : PIN301 pin ⑥ (TP404)
 CH-2 : VIDEO IN (TP405)
 1) Switch the input selector to LINE.
 2) Apply a color bar signal or 100% white signal to the VIDEO IN jack.
 3) Adjust SFR301 so that the synchro signal level of the Y-FM level is as shown in the figure below in the E-E mode.

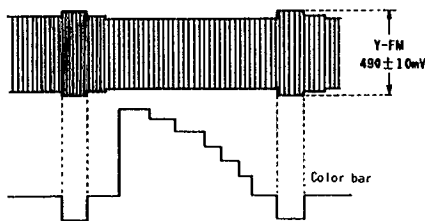

- (7) Chroma Recording Current Adjustment ([A] MAIN C.B)
 Oscilloscope : PIN301 pin ④ (TP406)
 1) Switch the input selector to LINE.
 2) Apply a color bar signal to the VIDEO IN jack.
 3) Set the VCR to the record mode and adjust SFR431 so that the burst level is as shown in the figure below.

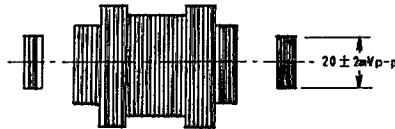

3. Audio Circuit Adjustment

- (1) Recording Bias Current Adjustment ([A] MAIN C.B)
 VTVM HOT terminal : TP701
 GND terminal : TP702
 1) Switch the input selector to LINE.
 2) Set the VCR to the no signal input state (with no input connected to the LINE AUDIO IN jack).
 3) Set the VCR to the record mode and adjust SFR701 so that the bias level is within the specification, $22 \pm 1 mV_{RMS}$.

MECHANICAL ADJUSTMENT

1. TAPE TRANSPORT ADJUSTMENT FLOWCHART

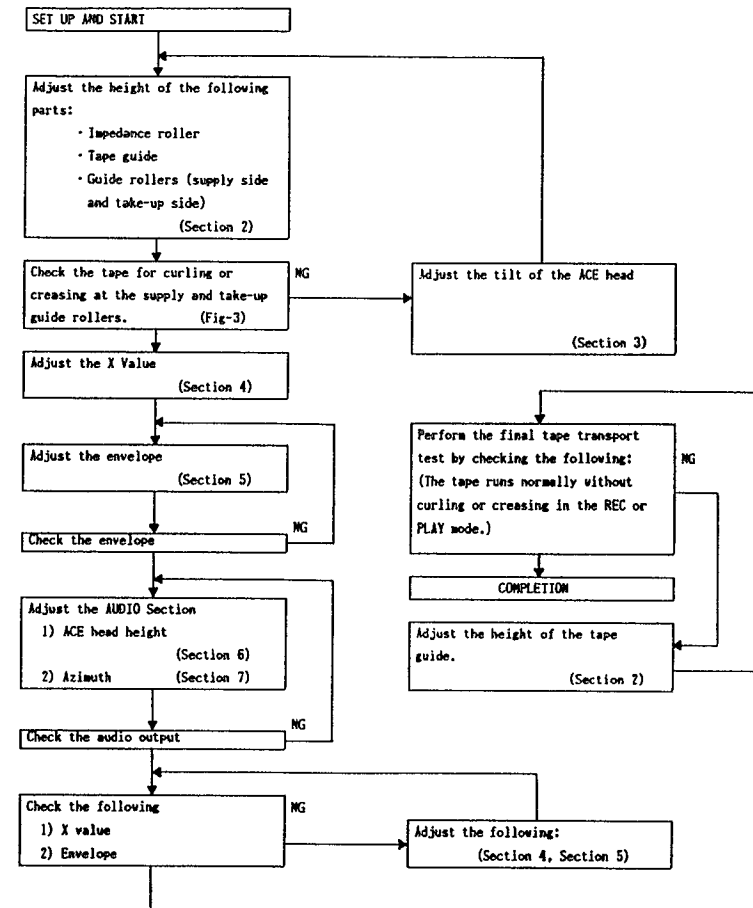

2. TAPE RUNNING POSITION ADJUSTMENT (GUIDE ROLLER/TAPE GUIDE/IMPEDANCE ROLLER)

Set-up

Lift the "Main circuit board".

1. Perform the height adjustment for the following items to obtain the proper tape running position. (See Figure-1)
 - ① Impedance roller
 - ② Guide roller (Supply side)
 - ③ Guide roller (Take-up side)
 - ④ Tape guide

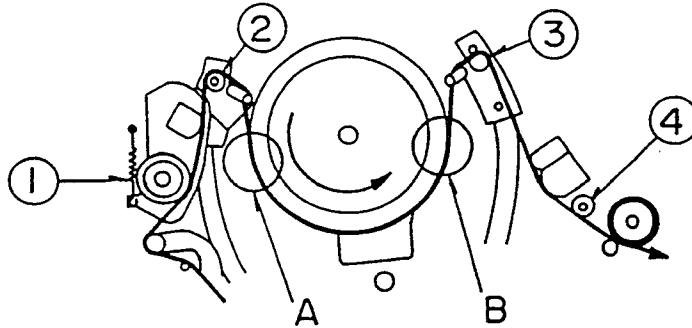

Fig.-1

2. Load a blank tape and set it to the PLAY mode. Check the tape transport at points "A" and "B" as shown in Fig-1.
3. Operate it between the PLAY and STOP modes several times.
4. Observe the tape transport at the "Lead surface of the cylinder" during the PLAY mode, and confirm that the tape runs smoothly along the "Lead surface of the cylinder" without slipping downward or upward. (See Figure-2)

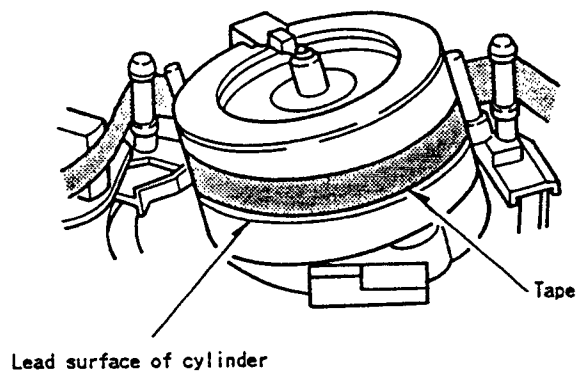

Fig-2

5. During loading, play and unloading, observe the tape at the supply and take-up "Guide rollers", "Tape guide" and "Impedance roller". Confirm that there is no curling or creasing etc., as shown in Fig-3.

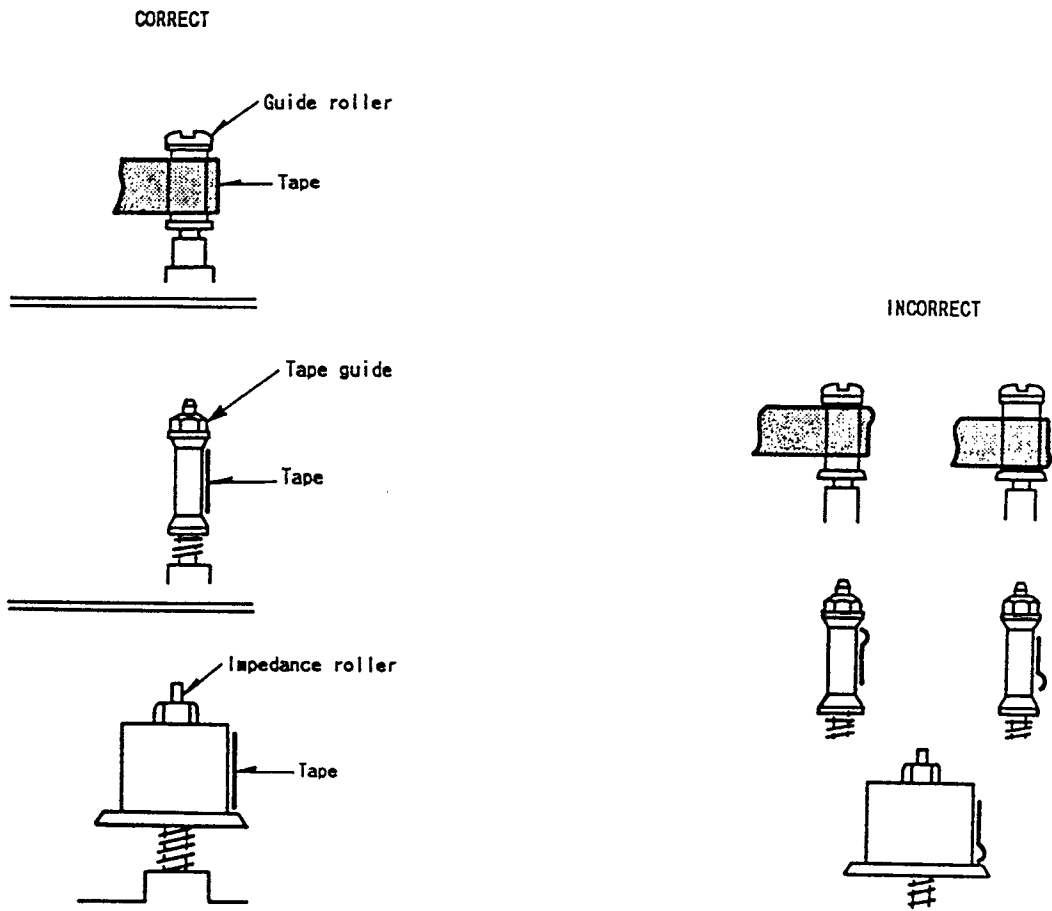

Fig-3

6. If any curling or creasing is noted, adjust "Tape guide roller" and "Impedance roller" first. In this case, adjust the "Impedance roller" in both PLAY and REV modes so that the tape runs as shown in Fig-4.

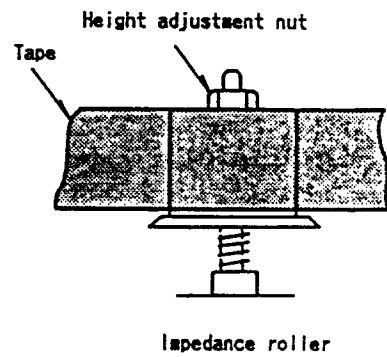

Fig-4

7. Next, adjust the "Guide roller" height. Insert the adjustment driver (J2) into the "Guide roller" top.
 (See Figure-5)
 Adjust the height by turning the driver slightly so that the tape runs on the "Guide roller" as shown in Fig-3, and the lower edge of the tape runs along the "Lead surface of the cylinder".

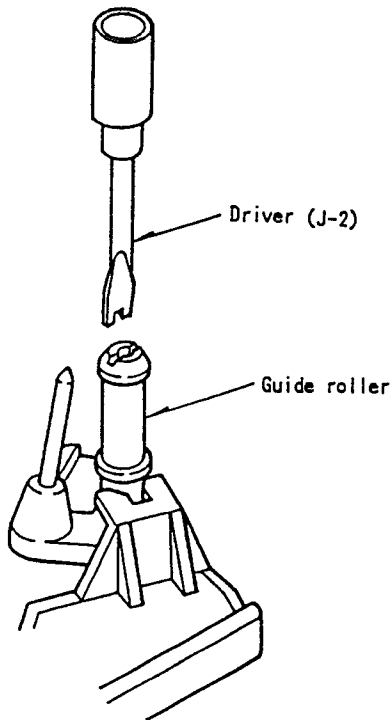

Fig-5

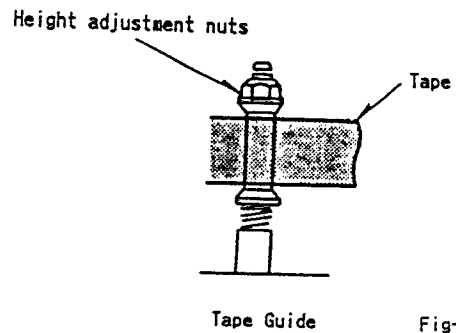

Fig-6

8. After completion of the supply side "Guide roller" adjustments, adjust "Tape guide" so that tape runs as shown in Fig-6 and adjust the take-up side "Guide roller" by using the same procedures as for the supply side adjustments. In this case, adjust the "Guide roller" height first.
9. Confirm that there is no curling or creasing at the "Impedance roller" (Both PLAY and REV modes). If there is any curling or creasing at the "Impedance roller", adjust the same procedures of Fig-6.
10. Finally, confirm that there is no curling or creasing at the take-up side guide roller and tape guide. If there is any curling or creasing between the take-up side "Guide roller" and the "ACE head", adjust the "ACE head".

3. ACE HEAD ADJUSTMENT

1. Load a recorded tape and set the it to PLAY mode.
2. Adjust the height of the edge of the "Audio track" on the "Audio control head" by using the height adjustment nut (A) and the "Tilt adjustment screw" (C) so that the tape transport is smooth at the "Take-up guide pole". Align the "Audio control head" height. (See Figure-7)

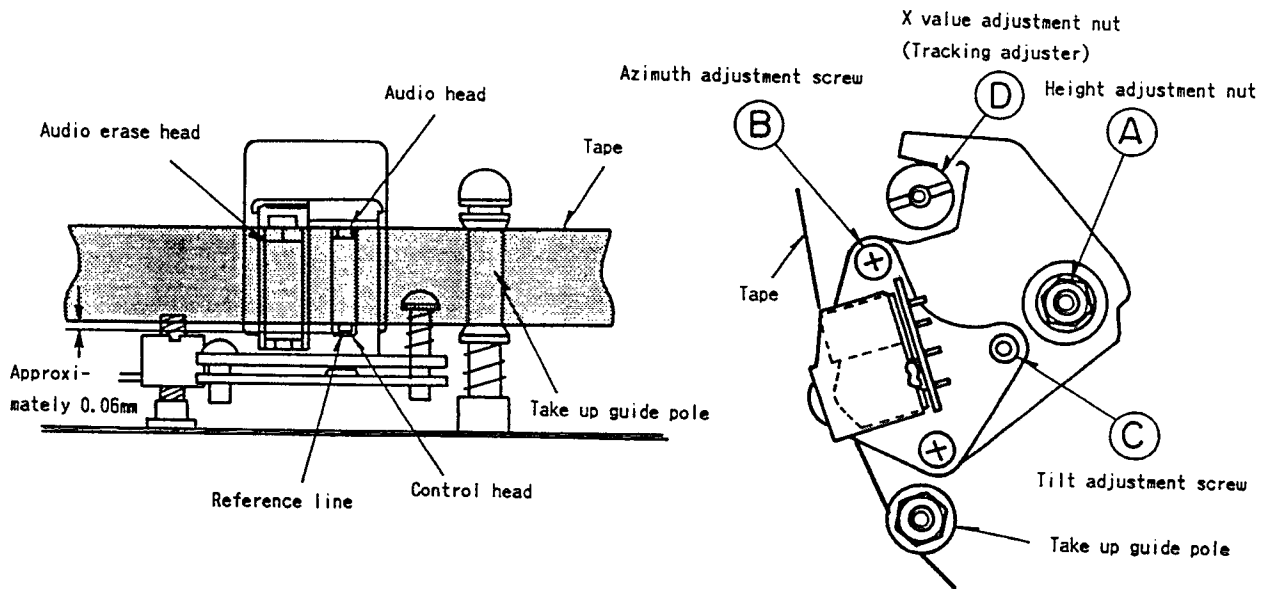

Fig-7

3. The fine adjustment is not required at this time.
The following conditions are sufficient :
 - (a) Proper tape transport between the "Audio control head" and the "Take-up guide pole".
 - (b) Stable SERVO system operation (proper pickup of tape's recorded control signal).

4. X VALUE ADJUSTMENT (PB FM PEAK ADJUSTMENT)

MEASURING METHOD

Measuring Point	Measuring Equip.	ADJ. Condition
MAIN C.B IC301 26 pin (Y PB FM) SERVO/SYSCON C.B IC201 10 pin (RF SWP)	Oscilloscope	PLAY (SP) MODE Test tape TTV-P2
ADJ. Location		ADJ. Value
X value adjustment nut		Maximum level (CH1 PB Y FM signal)

TEST EQUIPMENT CONNECTING DIAGRAMS

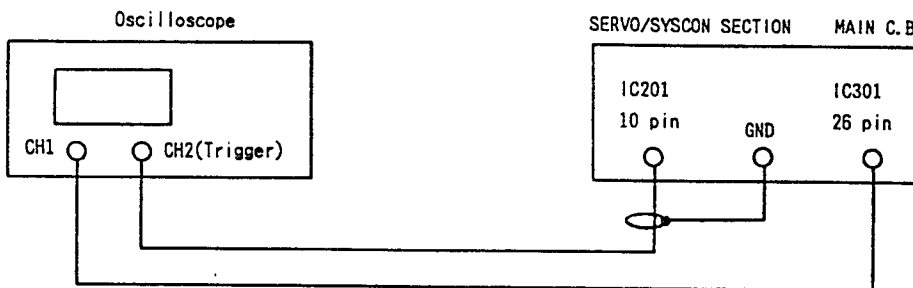

Fig-8

1. Connect the equipment as shown in Fig-8.
2. Adjust RV901 (Tracking volume) to its center position. (clockwise)
3. Adjust the "X value adjustment nut (D)" for maximum PB FM Signal for CH1 by using TTV-P2 test tape. (See Figure-9)
4. After adjusting the "X value", check that the output level of the PB FM Signal for CH1 changes symmetrically by rotating RV901 (Tracking volume).

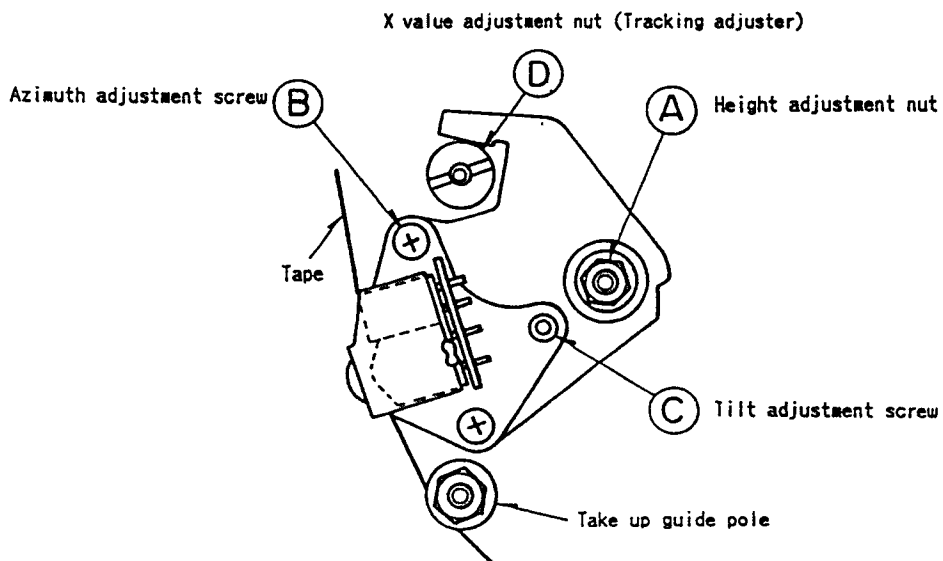

Fig-9

5. ENVELOPE WAVE FORM ADJUSTMENT

MEASURING METHOD

Measuring Point	Measuring Equip.	ADJ. Condition
MAIN C.B IC301 26 pin (Y PB FM) SERVO/SYSCON C.B IC201 10 pin (RF SWP)	Oscilloscope	PLAY (SP) MODE Test tape ITV-P2
ADJ. Location		ADJ. Value
Guide rollers		Maximum level and correct waveform (PB Y FM Signal)

TEST EQUIPMENT CONNECTING DIAGRAMS

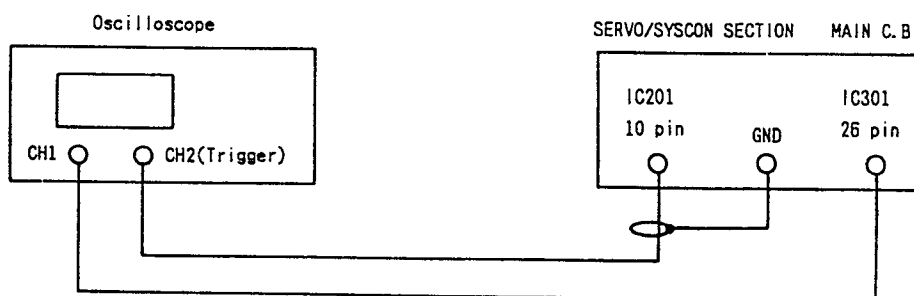

Fig.-10

1. Connect equipment as shown in Fig-10.
2. Playback the test tape ITV-P2.
3. The envelope waveform can be performed by adjusting the height of both the supply side and take-up side "Guide rollers".
Finally adjust the height of "Guide rollers" so that the envelope waveform is as flat as possible.
4. Set RV901 (Tracking Volume) to its center position and confirm that a nearly maximum level is obtained.
Then rotate the RV901 (Tracking Volume) in both directions while adjusting the height of "Guide rollers", in order to obtain the envelope waveform which is as flat as possible.
If the tape is above or lower the helical tape position, the envelope waveforms will take the shape as shown in Fig-11 and Fig-12.
5. Adjust for maximum flatness of the envelope waveform according to the Fig-11 and Fig-12.
6. After adjustment, rotate RV901 (Tracking Volume) counterclockwise and clockwise, and check that the waveform changes symmetrically.
7. Check the tape curl. (Refer to Section 2)

	Tape is too high	
	Supply side	Take-up side
When the tracking volume is rotated counterclockwise and clockwise directions.		
		
Adjustment	Supply side "Guide roller" rotated clockwise direction (lowers "Guide roller") to flatten envelope.	Take-up side "Guide roller" rotated clockwise direction (lowers "Guide roller") to flatten envelope.

Fig-11



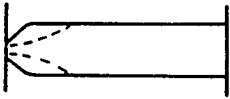
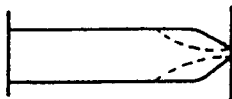
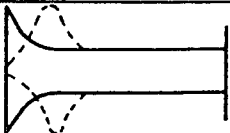
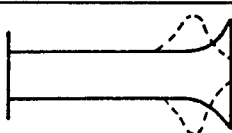

	Tape is too low	
	Supply side	Take-up side
When the tracking volume is rotated counterclockwise and clockwise directions.		
		
Adjustment	Supply side "Guide roller" rotated counterclockwise direction (raises "Guide roller") to flatten envelope.	Take-up side "Guide roller" rotated counterclockwise direction (raises "Guide roller") to flatten envelope.

Fig-12

6. ACE HEAD HEIGHT/ACE HEAD TILT ADJUSTMENT

MEASURING METHOD

Measuring Point	Measuring Equip.	ADJ. Condition
AUDIO OUTPUT	Oscilloscope AC voltmeter	PLAY (SP) MODE Test tape TTV-P1
ADJ. Location		ADJ. Value
Height adjustment nut		Maximum level (AC voltmeter)
Azimuth adjustment screw		
Tilt adjustment screw		

TEST EQUIPMENT CONNECTING DIAGRAMS

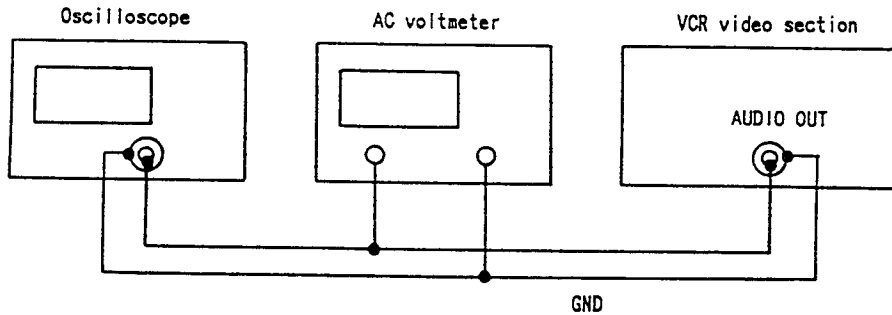

Fig-13

1. Connect equipment as shown in Fig-13.
2. Confirm that the running between the "Take-up guide roller" and the "ACE head" has no slack. If the tape has slack, take it up by turning the "Tilt adjustment screw (C)". (See Figure-15)
Then readjust "Guide roller" height in section 2 and the "X value" in section 4.
3. After confirming on the oscilloscope that a 1kHz audio signal is being output by playing back TTV-P1 test tape, adjust the "Height adjustment nut (A)" so that the AC voltmeter's reading is brought to its maximum level. (See Figure-7)
4. Adjust the "Azimuth adjustment screw (B)" so that the AC voltmeter's reading is brought to its maximum level. (See Figure-7)

7. ACE HEAD AZIMUTH ADJUSTMENT

MEASURING METHOD

Measuring Point	Measuring Equip.	ADJ. Condition
AUDIO OUTPUT	Oscilloscope AC voltmeter	PLAY (SP) MODE Test tape TTV-P2
ADJ. Location		ADJ. Value
Azimuth adjustment nut		Maximum level (AC voltmeter)

TEST EQUIPMENT CONNECTING DIAGRAMS

See Figure-13.

Fig-14

1. After confirming on the oscilloscope that a 6kHz audio signal is being output by playing back TTV-P2 test tape, adjust the "Azimuth adjustment screw (B)" so that the AC voltmeter's reading or oscilloscope waveform is brought to its maximum level. (See Figure-15)

Note : Fix the screw (B) and (C) with lock paint after readjustment.

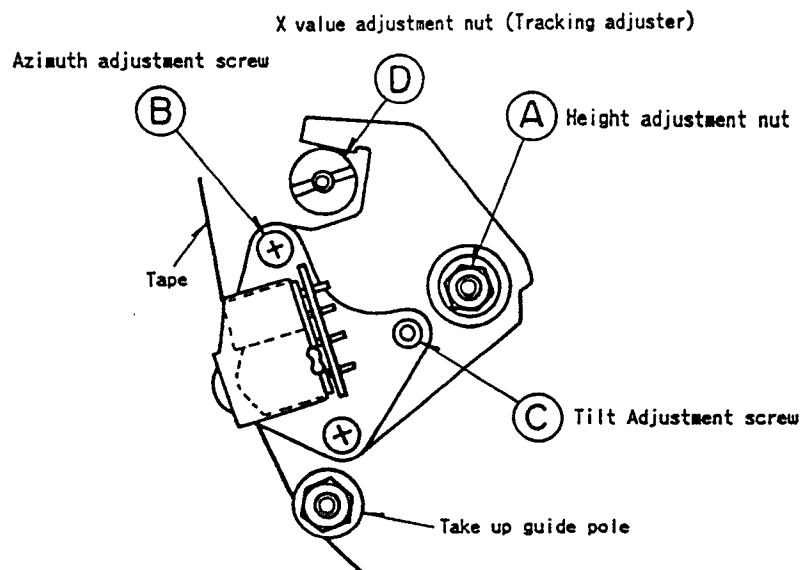
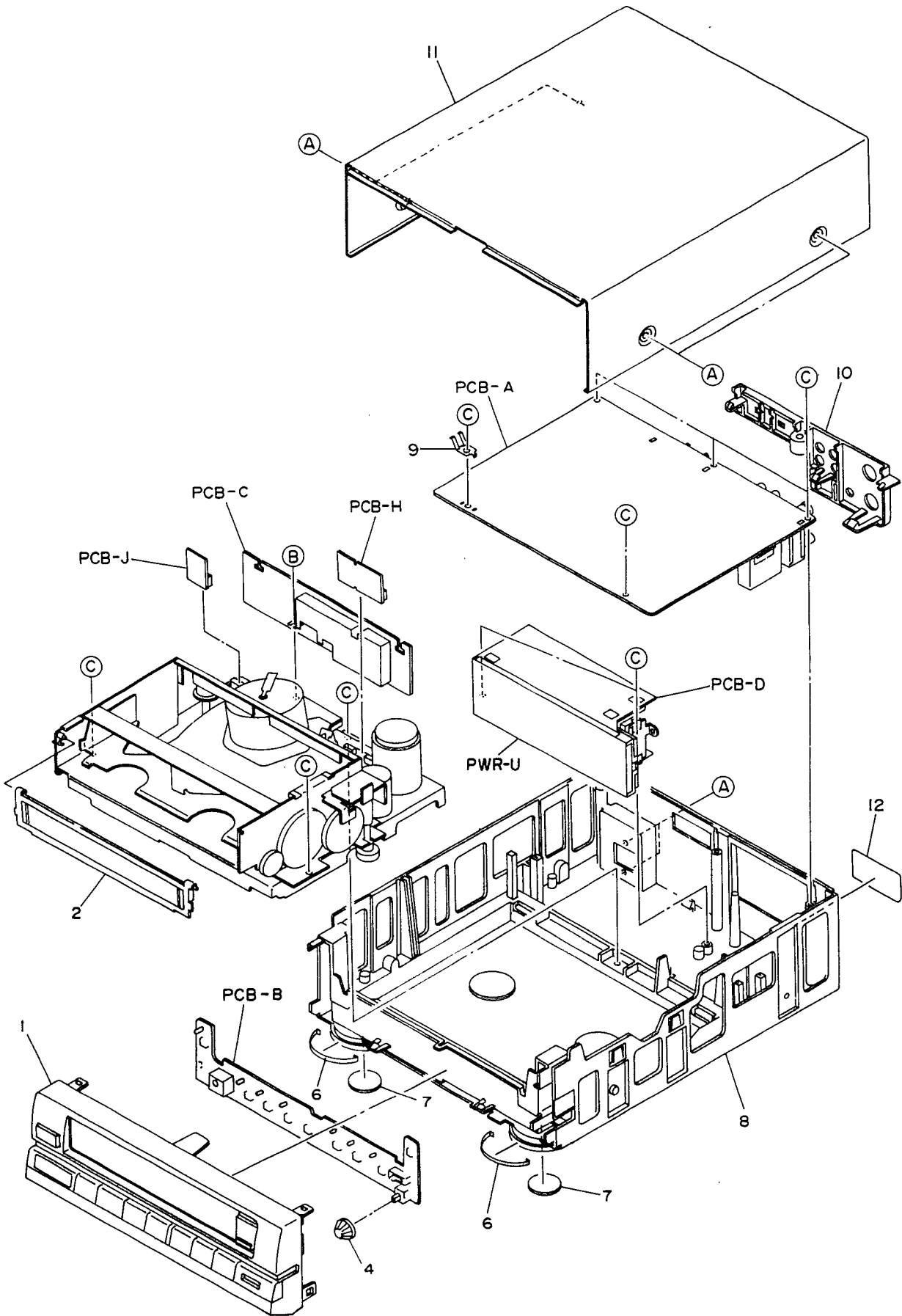

Fig-15

EXPLODED VIEW - 1



MECHANICAL PARTS LIST

EXPLODED VIEW..(1) CABINET PARTS LIST

REF. NO.	PARTS NO.	DESCRIPTION	REMARKS
1- 1	*9A02909340	CABINET FRONT ASSY,	
1- 2	*9A02532500	DOOR,CASSETTE 307	
1- 4	*9A02817700	KNOB,VOLUME	
1- 6	*9A02816800	PLATE,FOOT	
1- 7	*9A02816600	FOOT,	
1- 8	*9A02816500	CABINET,MAIN	
1- 9	*9A02818100	PLATE,EARTH	
1-10	*9A02818000	PLATE,REAR 339	
1-11	*9A02816700	CABINET,STEEL	
1-12	*9A02817900	PLATE,SPEC 339	
PCB-A	- - - - -	MAIN PCB ASSY,	
PCB-B	- - - - -	FRONT PCB ASSY,	
PCB-C	- - - - -	HEAD PCB ASSY,	
PCB-D	- - - - -	POWER UNIT PCB ASSY,	
PCB-H	- - - - -	RELAY PCB ASSY-2,	
PCB-J	- - - - -	RELAY PCB ASSY-4,	
PWR-U	Δ *9A02818240	POWER UNIT,9EV	
(A)	9A02426800	SCREW,BVT2+3-8W/O SLO.BLK	
(B)	9A02427000	SCREW,BVIT3+2.6-8	
(C)	9A02426900	SCREW,BVIT3B+3-10	

EXPLODED VIEW..(2) MECHANICAL PARTS LIST

REF. NO.	PARTS NO.	DESCRIPTION	REMARKS
	*9A02427100	MERCHA UNIT,TN5900P2SRN 104	
2- 1	*9A02492800	CYLINDER ASSY	
2- 2	*9A02492900	UPPER DRUM	
2- 3	*9A02493000	LOWER DRUM ASSY	
2- 4	*9A02493100	CYLINDER MOUNT	

Parts marked with *require longer delivery time

EXPLODED VIEW - 2

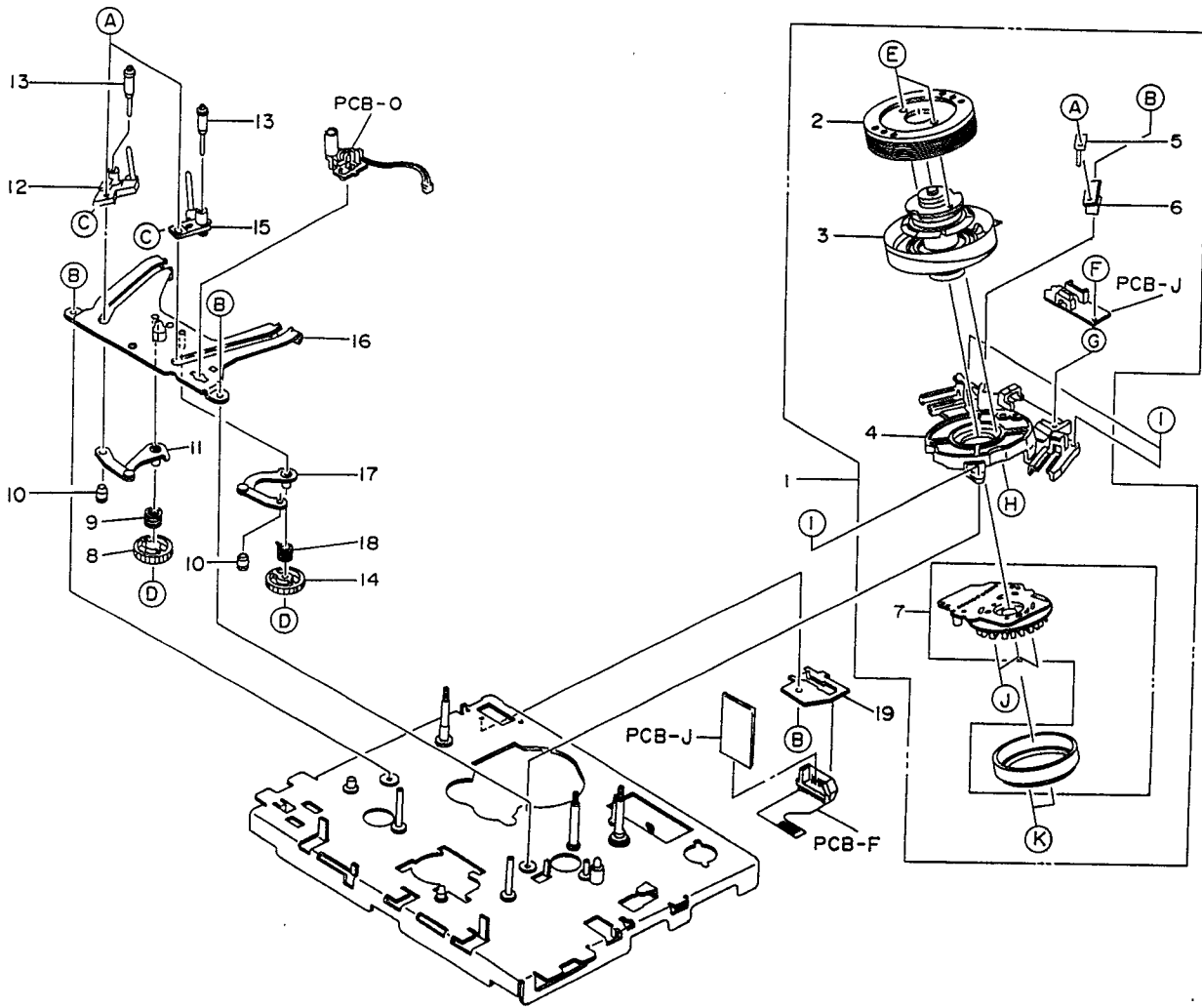

REF. NO.	PARTS NO.	DESCRIPTION	REMARKS
2- 5	*9A02493200	DRUM EARTH	
2- 6	*9A02493300	DRUM EARTH BRACKET	
2- 7	*9A02493400	MOTOR TM82	
2- 8	*9A02493500	T LOADING GEAR L	
2- 9	*9A02493600	LOADING GEAR SPRI.L	
2-10	*9A02493700	LOADING BOSS	
2-11	*9A02493800	LOADING PLATE L SEMI ASSY	
2-12	*9A02493900	LOADING BLOCK L	
2-13	*9A02494000	ROLLER POST ST	
2-14	*9A02494100	T LOADING GEAR R	
2-15	*9A02494200	LOADING BLOCK R	
2-16	*9A02494300	LOADI.BASE SEMI ASSY	
2-17	*9A02494400	LOADING PLATE R SEMI ASSY	
2-18	*9A02494500	LOADING GEAR SPRI.R	
2-19	- - - - -	CONNECTOR BRACKET	

Parts marked with *require longer delivery time

EXPLODED VIEW..(2) MECHANICAL PARTS LIST

REF. NO.	PARTS NO.	DESCRIPTION	REMARKS
PCB-F	- - - - -	RELAY PCB ASSY-1	
PCB-I	- - - - -	RELAY PCB ASSY-3	
PCB-J	- - - - -	RELAY PCB ASSY-4	
PCB-O	- - - - -	LED PCB ASSY	
(A)	9A02491700	CUP SCREW M2.6X3	
(B)	9A02491800	C TAPPI.SCREW 2.6X5	
(C)	9A02491900	SET SCR.2.0X3(PLANE)	
(D)	9A02492000	PW CUT 2.6X6X0.5	
(E)	9A02492100	BIND TAMS SCREW 3X8	
(F)	9A02492200	W TAMS SCREW 2.6X6	
(G)	9A02492300	WASHER 2.6	
(H)	9A02492400	SCREW(FOR CAMERA)2X5	
(I)	9A02492500	C TAPPING SCREW3X10	
(J)	9A02492600	SCREW 2.6X2.0	
(K)	9A02492700	TAMS SCREW 2.6X6	

EXPLODED VIEW..(3) MECHANICAL PARTS LIST

REF. NO.	PARTS NO.	DESCRIPTION	REMARKS
3- 1	*9A02495500	BT ACTUATE PLA.SPRI.	
3- 2	*9A02495600	S SOFT BRAKE ASSY	
3- 3	*9A02495700	S SOFT BRAKE SPRING	
3- 4	*9A02495800	BAND HOLDER SPRING	
3- 5	*9A02495900	BT BAND ASSY	
3- 6	*9A02496000	BAND HOLDER COLLAR	
3- 7	*9A02496100	BT ARM SEMI ASSY	
3- 8	*9A02496200	BACK TENSION SUPPOR.	
3- 9	*9A02496300	DAMPER RUBBER	
3-10	*9A02496400	TRACKING ADJUSTER	
3-11	*9A02496500	TAPE GUIDE SPRING	
3-12	*9A02496600	TAPE GUIDE FLANGE D	
3-13	*9A02496700	TAPE GUIDE	
3-14	*9A02496800	TAPE GUIDE FLANGE C	
3-15	*9A02496900	GUIDE CAP	
3-16	*9A02497000	OPEN ANGLE ASSY	
3-17	*9A02497100	DEW SENSOR EYH-SIOR	
3-18	*9A02497200	BRAKE ACTUATE BASE SPRING	
3-19	*9A02497300	BRAKE ACTUATE BASE	
3-20	*9A02497400	BRAKE PLATE	
3-21	*9A02497500	BRAKE PLATE SPRING	
3-22	*9A02497600	TRIGGER LEVER	
3-23	*9A02497700	TRIGGER HOOK	
3-24	*9A02497800	TRIGGER LEVER SPRIN.	
3-25	*9A02497900	REEL ASSY	
3-26	*9A02498000	RG SLIDE PLA.COLLAR	
3-27	*9A02498100	RG SLIDE PLATE	
3-28	*9A02498200	RG SLIDE SPRING	
3-29	*9A02498300	RG SLIDE BASE	
3-30	*9A02498400	METAL HOUSING ASSY	

Parts marked with *require longer delivery time

EXPLODED VIEW..(3) MECHANICAL PARTS LIST

REF. NO.	PARTS NO.	DESCRIPTION	REMARKS
3-31	*9A02498500	RG ARM SEMI ASSY	
3-32	*9A02498600	CAPSTAN MOTOR ASSY	
(A)	9A02494600	PW CUT 2.1X4X0.5	
(B)	9A02494700	PW CUT 2.1X5X0.5	
(C)	9A02494800	C TAPPING SCREW 2.6X4	
(D)	9A02494900	NUT 3.0	
(E)	9A02495000	TAMS SCREW 2.6X4	
(F)	9A02495100	PW 3.1X6X0.5	
(G)	9A02495200	TAMS SCREW 3X4	
(H)	9A02495300	C TAPPING SCREW 2.6X8	
(I)	9A02495400	NYLON WAS. 2.92X5X0.5	
(J)	9A02492000	PW CUT 2.6X6X0.5	

Parts marked with *require longer delivery time

EXPLODED VIEW - 3

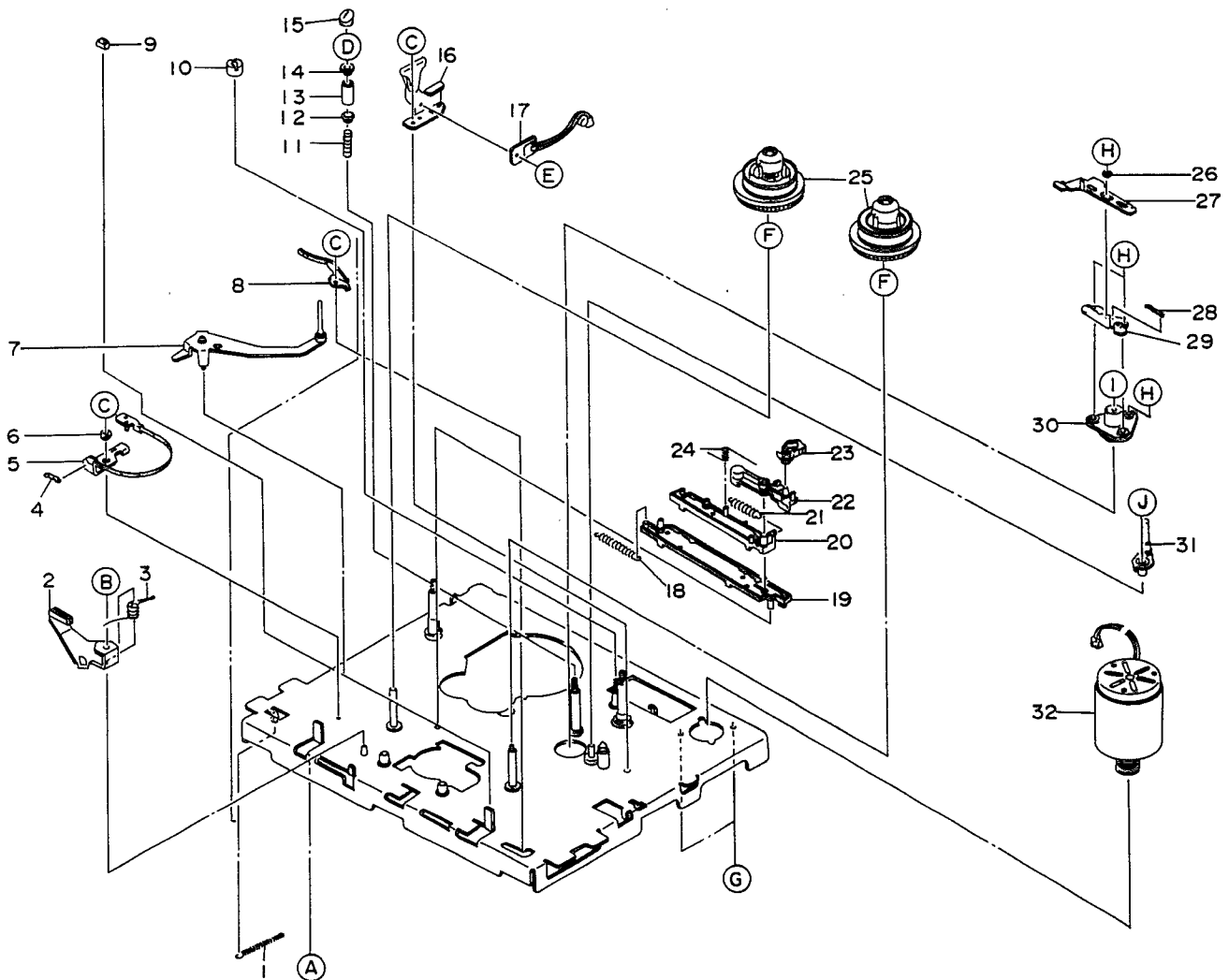

EXPLODED VIEW - 4

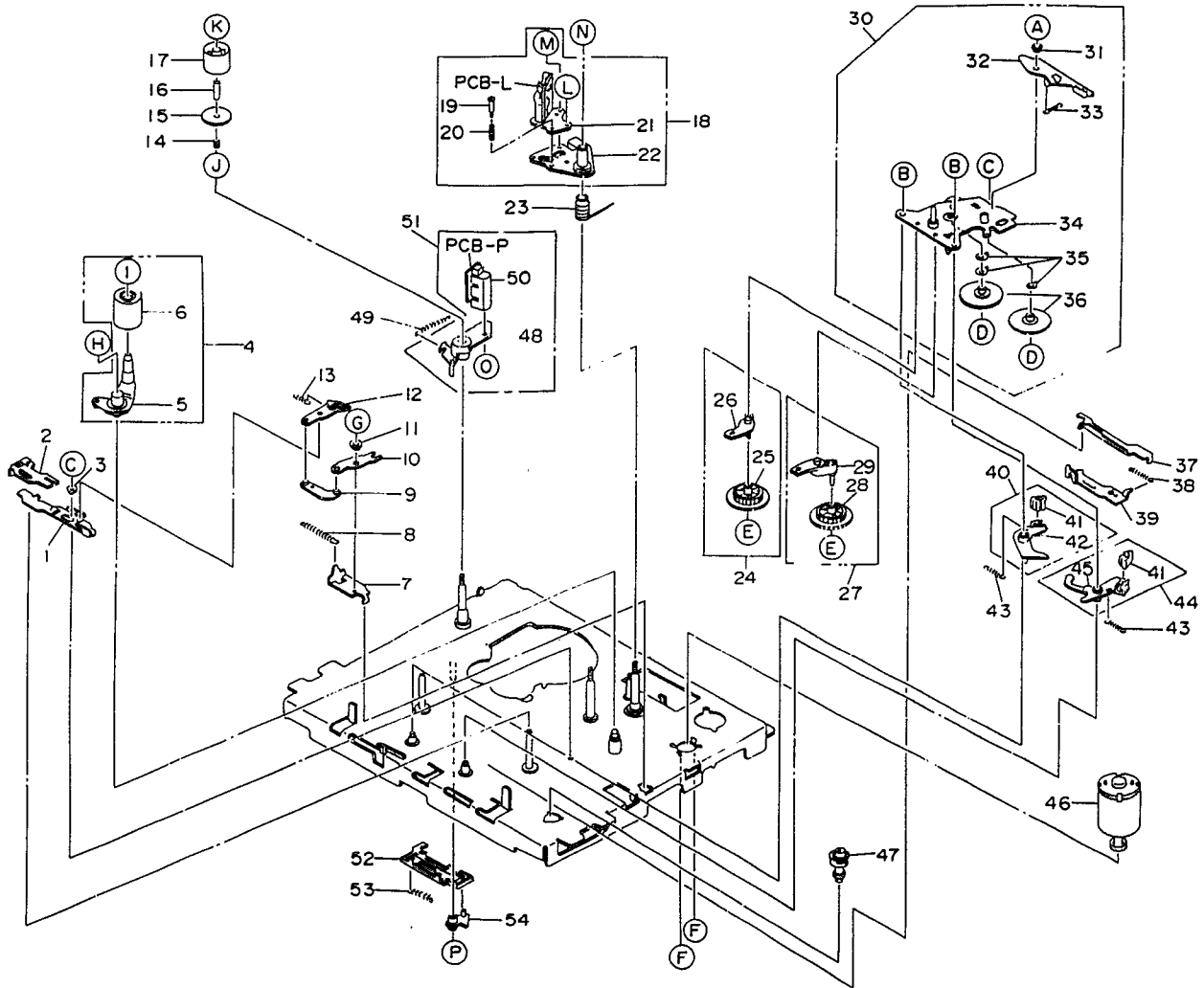

EXPLODED VIEW..(4) MECHANICAL PARTS LIST

REF. NO.	PARTS NO.	DESCRIPTION	REMARKS
4- 1	*9A02499700	P SLIDE PLATE A	
4- 2	*9A02499800	P SLIDE PLATE B	
4- 3	*9A02499900	COLLAR	
4- 4	*9A02500000	PINCH ROLLE.ARM ASY	
4- 5	*9A02500100	PINCH ROLLER ARM SEMI ASY	
4- 6	*9A02500200	PINCH ROLLER A	
4- 7	*9A02500300	P ANGLE HOLDER	
4- 8	*9A02500400	P-SPRING, ROLLER	
4- 9	*9A02500500	JOINT PLATE	
4-10	*9A02500600	P ACTUATE ANGLE	
4-11	*9A02499900	COLLAR	
4-12	*9A02500700	P ACTUATE ARM	
4-13	*9A02500800	P-SPRING,ACTUAT.ARM	
4-14	*9A02500900	TAPE GUIDE FLANGE SPRING	
4-15	*9A02501000	TAPE GUIDE FLANGE A	

Parts marked with *require longer delivery time

EXPLODED VIEW..(4) MECHANICAL PARTS LIST

REF. NO.	PARTS NO.	DESCRIPTION	REMARKS
4-16	*9A02501100	IMPEDANCE ROLLER SLEEVE	
4-17	*9A02501200	IMPEDANCE ROLLER	
4-18	*9A02501300	HEAD BASE ASSY	
4-19	- - - - -	AZIMUTH SPRING SCREW	
4-20	- - - - -	AZIMUTH SPRING	
4-21	*9A02501400	ACE HEAD HV225211	
4-22	- - - - -	HEAD BASE SEMI ASSY	
4-23	- - - - -	HEAD SPRING	
4-24	*9A02501500	P GEAR ASSY	
4-25	*9A02501600	PLAY GEAR	
4-26	*9A02501700	P GEAR ARM ASSY	
4-27	*9A02501800	RF GEAR ASSY	
4-28	*9A02501900	FF GEAR	
4-29	*9A02502000	RF GEAR ARM ASSY	
4-30	*9A02502100	SUB PLATE ASSY	
4-31	*9A02502200	T SOFT BRAKE ARM COLLAR	
4-32	*9A02502300	T SOFT BRAKE ASSY	
4-33	*9A02502400	T-SPRING, SOFT BRAKE ARM	
4-34	- - - - -	SUB PLATE SEMI ASSY	
4-35	*9A02502500	WAVE WASHER	
4-36	*9A02502600	REEL DRIVE GEAR	
4-37	*9A02502700	BRAKE LIFTER	
4-38	*9A02502800	L BRAKE ACTUATOR SPRING	
4-39	*9A02502900	L BRAKE ACTUATOR	
4-40	*9A02503000	S BRAKE ARM ASSY	
4-41	*9A02503100	BRAKE SHOE	
4-42	*9A02503200	S BRAKE ARM	
4-43	*9A02503300	BRAKE ARM SPRING	
4-44	*9A02503400	T BRAKE ARM ASSY	
4-45	*9A02503500	T BRAKE ARM	
4-46	*9A02503600	LM ASSY	
4-47	*9A02503700	TRIGGER BEARING ASSY	
4-48	- - - - -	FE PLATE	
4-49	*9A02503800	FE PLATE SPRING	
4-50	*9A02503900	FE HEAD HVFMD 0006	
4-51	*9A02504000	FE PLATE ASSY	
4-52	*9A02504100	FE SLIDE PLATE	
4-53	*9A02504200	FE ACTUATE SPRING	
4-54	*9A02504300	FE ACTUATE LEVER	
PCB-L	- - - - -	ACE HEAD PCB ASSY	
PCB-P	- - - - -	ERASE HEAD ASSY	
(A)	9A02498700	SL FH SCREW 2X3	
(B)	9A02498800	TAMS SCREW 2X4	
(C)	9A02491800	C TAPPI.SCREW 2.6X5	
(D)	9A02498900	E RING S1.5	
(E)	9A02499000	PW CUT 1.6X3.8X0.3	
(F)	9A02495200	TAMS SCREW 3X4	
(G)	9A02495000	TAMS SCREW 2.6X4	
(H)	9A02499100	PW CUT 5X8X0.5	
(I)	9A02499200	SCREW 2.6X4	
(J)	9A02499300	PLANE WASHER3X8X0.5	
(K)	9A02499400	NYLON NUT M3	

Parts marked with *require longer delivery time

EXPLODED VIEW..(4) MECHANICAL PARTS LIST

REF. NO.	PARTS NO.	DESCRIPTION	REMARKS
(L)	9A02499500	SCREW 3.6 (SHAPE TYPE)	
(M)	9A02499600	LONG LOCK SCREW 2.6X7	
(N)	9A02499400	NYLON NUT M3	
(O)	9A02539500	SCREW FLANGE 2X3	
(P)	9A02494700	PW CUT 2.1X5X0.5	

Parts marked with *require longer delivery time

EXPLODED VIEW - 5

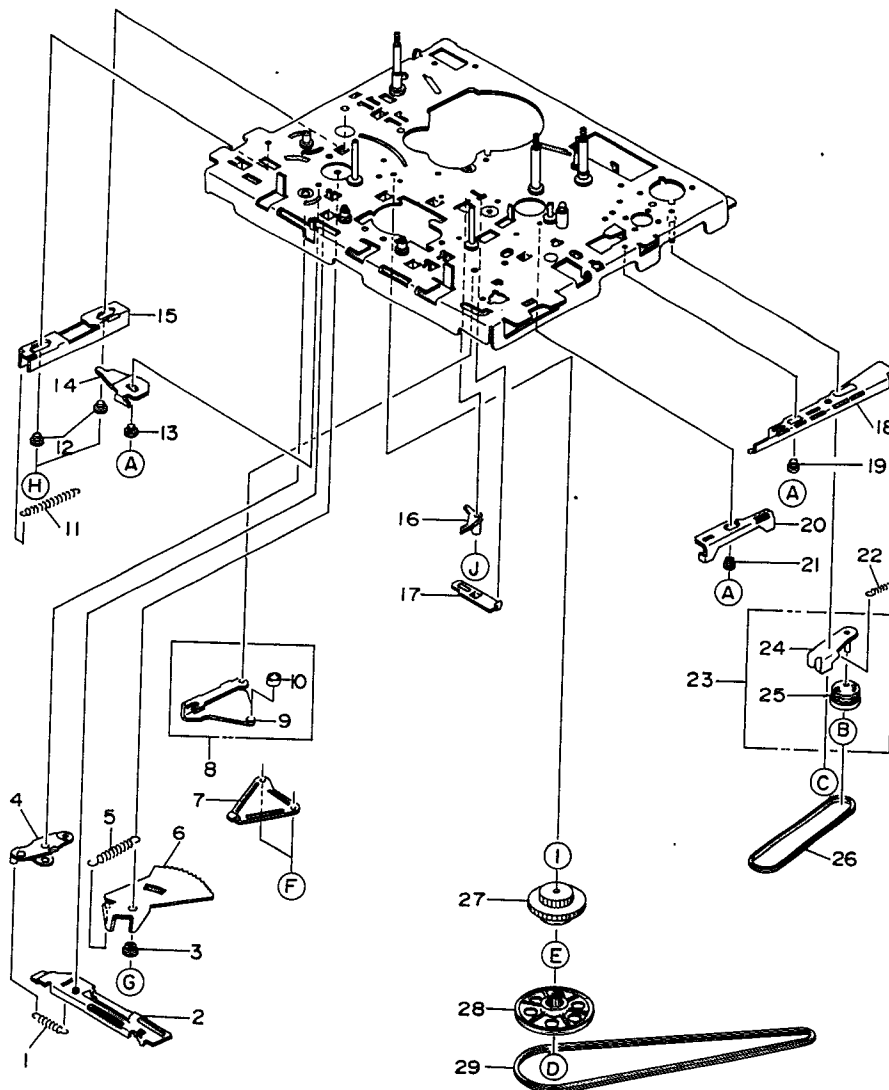

EXPLODED VIEW..(5) MECHANICAL PARTS LIST

REF. NO.	PARTS NO.	DESCRIPTION	REMARKS
5- 1	*9A02504900	LOADING ACTUATOR SPRING	
5- 2	*9A02505000	LOADING ACTUATOR SEMI ASSY	
5- 3	*9A02505100	L GEAR PLATE COLLAR	
5- 4	*9A02505200	LOAD.ACTUA.LEVER SEMI ASSY	
5- 5	*9A02505300	L GEAR PLATE SPRING	
5- 6	*9A02505400	L GEAR PLATE	
5- 7	*9A02505500	LOAD.LEVER REINFORC.PLATE	
5- 8	*9A02505600	LOADING LEVER ASSY	
5- 9	- - - - -	LOADING LEVER SEMI ASSY	
5-10	- - - - -	CAM ROLLER	
5-11	*9A02505700	BACK TENSION SPRING	
5-12	*9A02505800	BT ACTUATE PLATE COLLAR	
5-13	*9A02499900	COLLAR	
5-14	*9A02505900	BT ACTUATE LEVER	
5-15	*9A02512100	BT ACTUATE PLATE	
5-16	*9A02506000	RG ACTUATE ARM	
5-17	*9A02506100	RG ACTUATE	
5-18	*9A02506200	L BRAKE PLATE	
5-19	*9A02499900	COLLAR	
5-20	*9A02506300	EJECT ACTUATOR	
5-21	*9A02499900	COLLAR	
5-22	*9A02506400	IDLER ARM SPRING	
5-23	*9A02506500	E IDLER ARM ASSY	
5-24	- - - - -	E IDLER ARM SEMI ASSY	
5-25	- - - - -	EJECT PULLEY	
5-26	*9A02506600	FL BELT	
5-27	*9A02506700	CLUTCH ASSY	
5-28	*9A02506800	MIDDLE PULLEY ASSY	
5-29	*9A02506900	DRIVE BELT	
(A)	9A02491800	C TAPPI.SCREW 2.6X5	
(B)	9A02499000	PW CUT 1.6X3.8X0.3	
(C)	9A02494700	PW CUT 2.1X5X0.5	
(D)	9A02492000	PW CUT 2.6X6X0.5	
(E)	9A02504400	NYLON WA.2.98X6X0.3	
(F)	9A02504500	TAMS SCREW 2X5	
(G)	9A02504600	C TAPPING SCREW 3X6	
(H)	9A02504700	S TAPP.SCREW2.6X3.5	
(I)	9A02504800	NYLON WAS.3.1X6X0.3	
(J)	9A02494700	PW CUT 2.1X5X0.5	

EXPLODED VIEW..(6) MECHANICAL PARTS LIST

REF. NO.	PARTS NO.	DESCRIPTION	REMARKS
6- 1	*9A02507400	LOADING BELT	
6- 2	*9A02507500	LOADING PULLEY	
6- 3	*9A02507600	LOADING CAM ASSY	
6- 4	- - - - -	LOADING CAM	
6- 5	- - - - -	S BRUSH	

Parts marked with *require longer delivery time

EXPLODED VIEW - 6

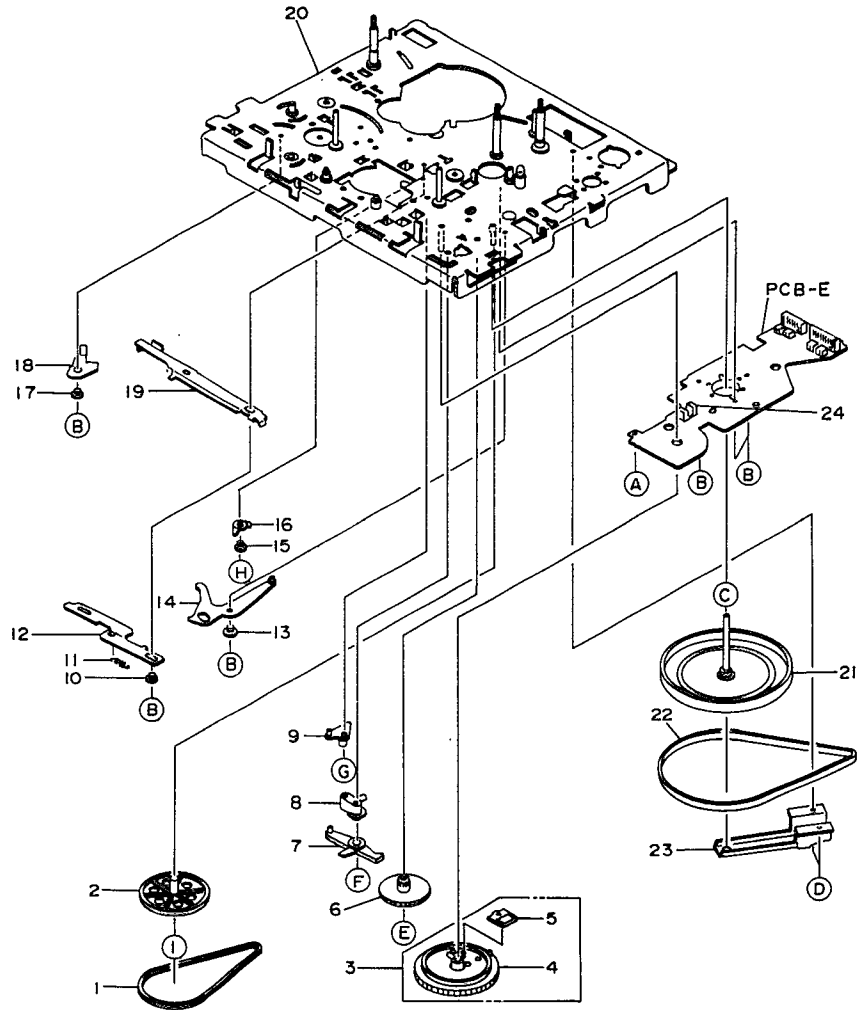

REF. NO.	PARTS NO.	DESCRIPTION	REMARKS
6-6	*9A02507700	LOADING GEAR	
6-7	*9A02507800	EJECT ARM	
6-8	*9A02507900	BRAKE ACTUATE ARM	
6-9	*9A02508000	SEARCH ARM B	
6-10	*9A02508100	P SLIDER COLLAR	
6-11	*9A02508200	P-SPRING, SLIDER	
6-12	*9A02508300	P SLIDER	
6-13	*9A02508400	P CAM LEVER COLLAR	
6-14	*9A02508500	P CAM LEVE.SEMI ASY	
6-15	*9A02508600	P CRANK COLLAR	
6-16	*9A02508700	P CRANK	
6-17	*9A02499900	COLLAR	
6-18	*9A02508800	BT RETURN LEVER	
6-19	*9A02508900	BT CHANGE PLATE	
6-20	- - - - -	CHASSIS SEMI ASSY	
6-21	*9A02509000	FLYWHEEL CAPSTAN	
6-22	*9A02509100	MAIN BELT	
6-23	*9A02509200	FL ANGLE ASSY	
6-24	*9A02509300	REEL SENSOR	
PCB-E	- - - - -	BASE PCB ASSY	

Parts marked with *require longer delivery time

EXPLODED VIEW..(6) MECHANICAL PARTS LIST

REF. NO.	PARTS NO.	DESCRIPTION	REMARKS
(A)	9A02507000	S TAPPING SCREW 2.6X5	
(B)	9A02491800	C TAPPI.SCREW 2.6X5	
(C)	9A02495100	PW 3.1X6X0.5	
(D)	9A02507100	C TAPPING SCREW 3X5	
(E)	9A02494700	PW CUT 2.1X5X0.5	
(F)	9A02507200	PW CUT 2.6X8X0.5	
(G)	9A02492000	PW CUT 2.6X6X0.5	
(H)	9A02507300	C TAPP.FH SCREW 2.6X4	
(I)	9A02499000	PW CUT 1.6X3.8X0.3	

EXPLODED VIEW - 7

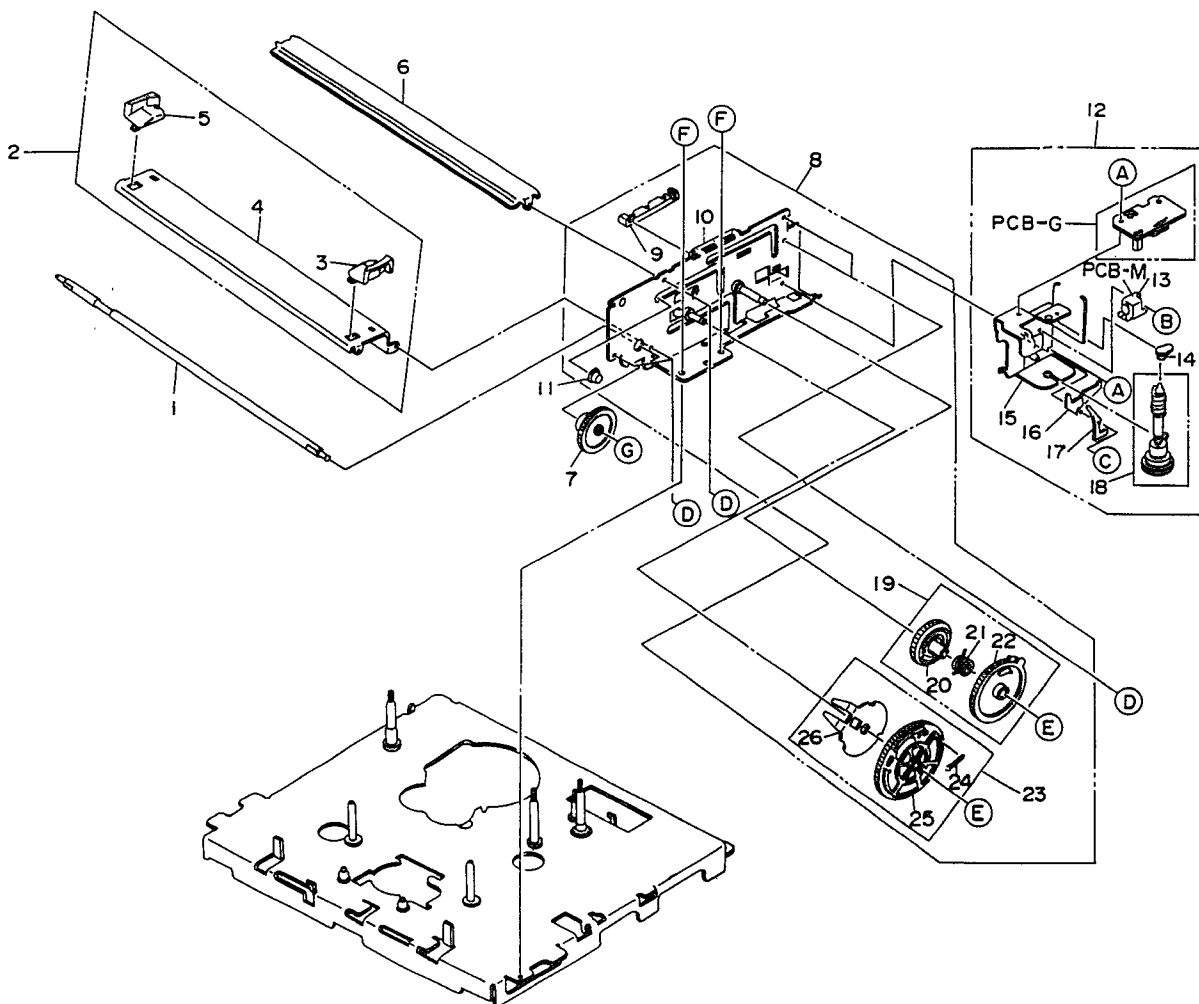

EXPLODED VIEW..(7) MECHANICAL PARTS LIST

REF. NO.	PARTS NO.	DESCRIPTION	REMARKS
7- 1	*9A02509500	SYNCHRONIZE SHAFT	
7- 2	- - - - -	FRONT ANGLE ASSY	
7- 3	*9A02509600	TAPE GUIDE R	
7- 4	*9A02509700	FRONT ANGLE	
7- 5	*9A02509800	TAPE GUIDE L	
7- 6	*9A02509900	UPPER PLATE	
7- 7	*9A02510000	SYNCHRONIZE GEAR A	
7- 8	*9A02510100	FRAME R ASSY	
7- 9	- - - - -	OPEN LEVER GUIDE	
7-10	- - - - -	FRAME R SEMI ASSY	
7-11	- - - - -	GUIDE SLEEVE	
7-12	*9A02510200	C LOAD BRACKET ASSY	
7-13	- - - - -	SENSOR PCB SEMI ASSY	
7-14	- - - - -	F WQRM BEARING A	
7-15	- - - - -	C COAD BRACKET SEMI ASSY	
7-16	- - - - -	IN SW LEVER	
7-17	- - - - -	S SW LEVER	
7-18	*9A02510300	F LOADIN.CLUTCH ASY	
7-19	*9A02510400	WORMWHEEL ASSY	
7-20	- - - - -	FRICTION GEAR	
7-21	- - - - -	FRICTION SPRING	
7-22	- - - - -	WOAM WHEEL	
7-23	*9A02510500	LIFT GEAR R ASSY	
7-24	- - - - -	LP SPRING	
7-25	- - - - -	LIFT GEAR R	
7-26	- - - - -	LIFT ARM	
PCB-G	- - - - -	SW PCB ASSY	
PCB-M	- - - - -	END SENSOR PCB ASSY	
(A)	9A02495000	TAMS SCREW 2.6X4	
(B)	9A02504500	TAMS SCREW 2X5	
(C)	9A02499000	PW CUT 1.6X3.8X0.3	
(D)	9A02495000	TAMS SCREW 2.6X4	
(E)	9A02509400	E RING S2.5	
(F)	9A02491800	C TAPPI.SCREW 2.6X5	
(G)	9A02509400	E RING S2.5	

Parts marked with *require longer delivery time

EXPLODED VIEW - 8

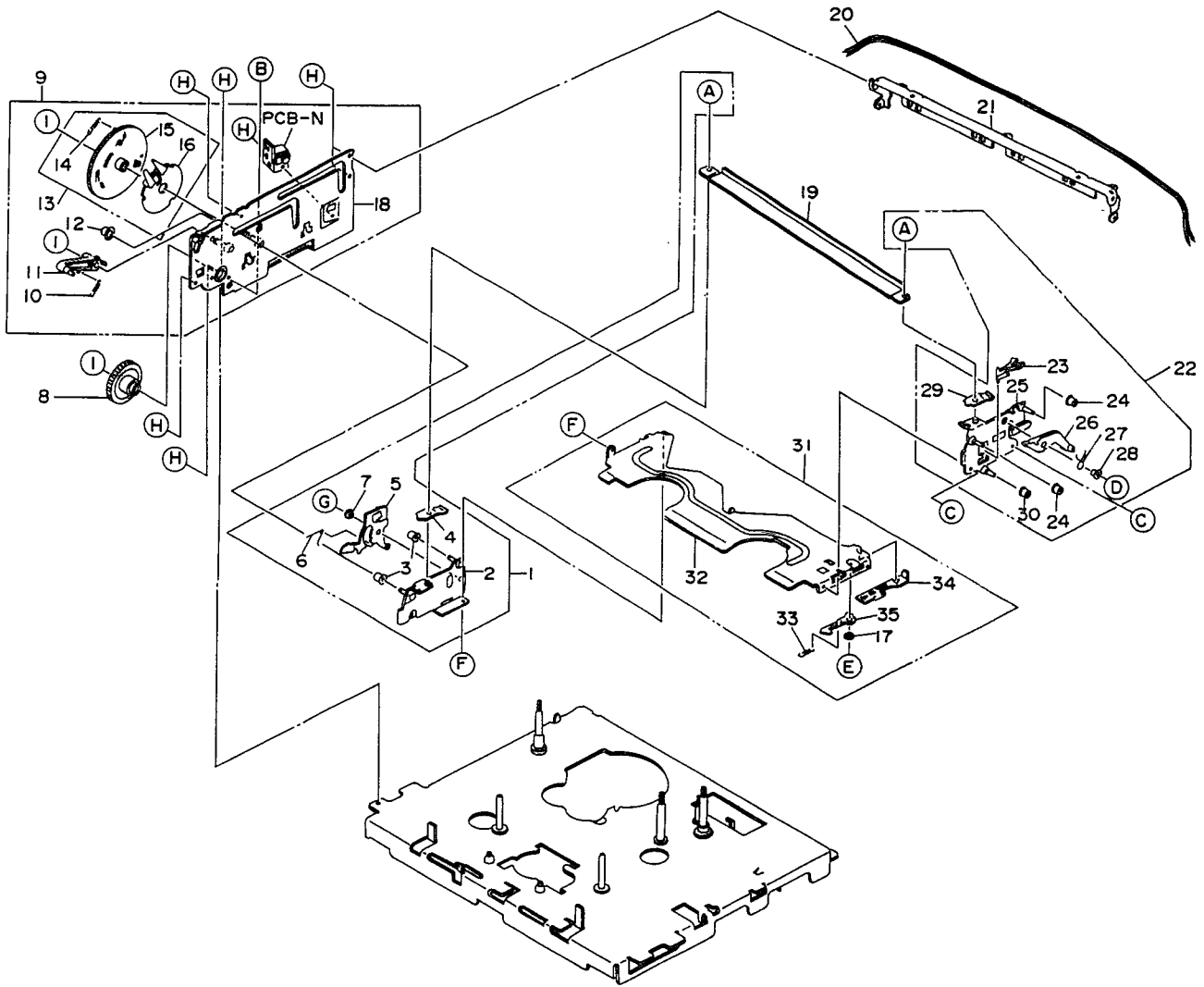

EXPLODED VIEW..(8) MECHANICAL PARTS LIST

REF. NO.	PARTS NO.	DESCRIPTION	REMARKS
8- 1	*9A02511200	SIDE PLATE L ASSY	
8- 2	- - - - -	SIDE PLATE SEMI ASSY	
8- 3	- - - - -	GUIDE ROLLER	
8- 4	- - - - -	CASSETTE PUSH PLATE	
8- 5	- - - - -	C LOCK PLATE L	
8- 6	- - - - -	LOCK PLATE SPRING L	
8- 7	- - - - -	LOCK PLATE COLLAR	
8- 8	*9A02510000	SYNCHRONIZE GEAR A	
8- 9	*9A02511300	FRAME L ASSY	
8-10	- - - - -	LIFT LEVER SPRING	
8-11	*9A02511400	LIFT LEVER	
8-12	- - - - -	GUIDE SLEEVE	
8-13	*9A02511500	LIFT GEAR L ASSY	
8-14	- - - - -	LP SPRING	
8-15	- - - - -	LIFT GEAR L	
8-16	- - - - -	LIFT ARM	
8-17	- - - - -	COLLAR	
8-18	- - - - -	FRAME L SEMI ASSY	
8-19	*9A02511600	TOP STAY	
8-20	- - - - -	ENG SENSOR WIRE	
8-21	*9A02511700	REAR ANGLE	
8-22	*9A02511800	SIDE PLATE R ASSY	
8-23	- - - - -	LOCK RELEASE LEVER	
8-24	- - - - -	GUIDE ROLLER	
8-25	- - - - -	SIDE PLATE R SEMI ASSY	
8-26	*9A02511900	OPEN LEVER	
8-27	- - - - -	OPEN LEVER SPRING	
8-28	- - - - -	OPEN LEVER COLLAR	
8-29	- - - - -	CASSETTE PUSH PLATE	
8-30	- - - - -	GUIDE ROLLER	
8-31	*9A02512000	CASSETTE HOLDER ASSY	
8-32	- - - - -	CASSETTE HOLDER	
8-33	- - - - -	LOCK SPRING	
8-34	- - - - -	SLIDE PLATE	
8-35	- - - - -	C LOCK PLATE A	
PCB-N	- - - - -	START SENSOR PCB ASSY	
(A)	9A02510600	SCREW 2.3X2	
(B)	9A02491800	C TAPPI,SCREW 2.6X5	
(C)	9A02510700	SCREW 2.6X3	
(D)	9A02510800	SL SCREW 2X4	
(E)	9A02510900	SL SCREW 2.6X3	
(F)	9A02511000	SCREW 2.3X2.5	
(G)	9A02511100	SL SCREW 2X2.5	
(H)	9A02495000	TAMS SCREW 2.6X4	
(I)	9A02509400	E RING S2.5	

Parts marked with *require longer delivery time

INCLUDED ACCESSORIES PARTS LIST

REF. NO.	PARTS NO.	DESCRIPTION	REMARKS
	9A02460200	CORD, RF PAL	
	9A02460300	AC CORD ASSY, AS	
	9A02460500	SUM-3, (MAXELL 2P)	
	*9A02823000	REMOCON, RC-417	
	*9A02629900	OWNER'S MANUAL, (E)	

Parts marked with *require longer delivery time

MV-339P

TEAC®

TEAC CORPORATION	Musashino Center Bldg., 1-19-18, Nakacho, Musashino-shi, Tokyo 180, Japan Phone: (0422) 52-5081
TEAC AMERICA, INC.	7733 Telegraph Road, Montebello, California 90640 Phone: (213) 726-0303
TEAC CANADA LTD.	340 Brunel RD, Mississauga, Ontario L4Z 2C2, Canada Phone: 416-890-8008
TEAC UK LIMITED	5 Marlin House, Marlins Meadow, The Croxley Centre, Watford, Herts, WD1 8YA, U.K. Phone: 0923-225235
TEAC DEUTSCHLAND GmbH	Bahnstrasse 12, 6200 Wiesbaden-Erbenheim, West Germany Phone: 0611-71580
TEAC FRANCE S.A.	17, Rue Alexis-de-Tocqueville CE 005 92182 Antony Cedex, France Phone: (1) 42.37.01.02
TEAC AUSTRALIA PTY., LTD.	106 Bay Street, Port Melbourne Victoria 3207, Australia Phone: (03) 646-1733

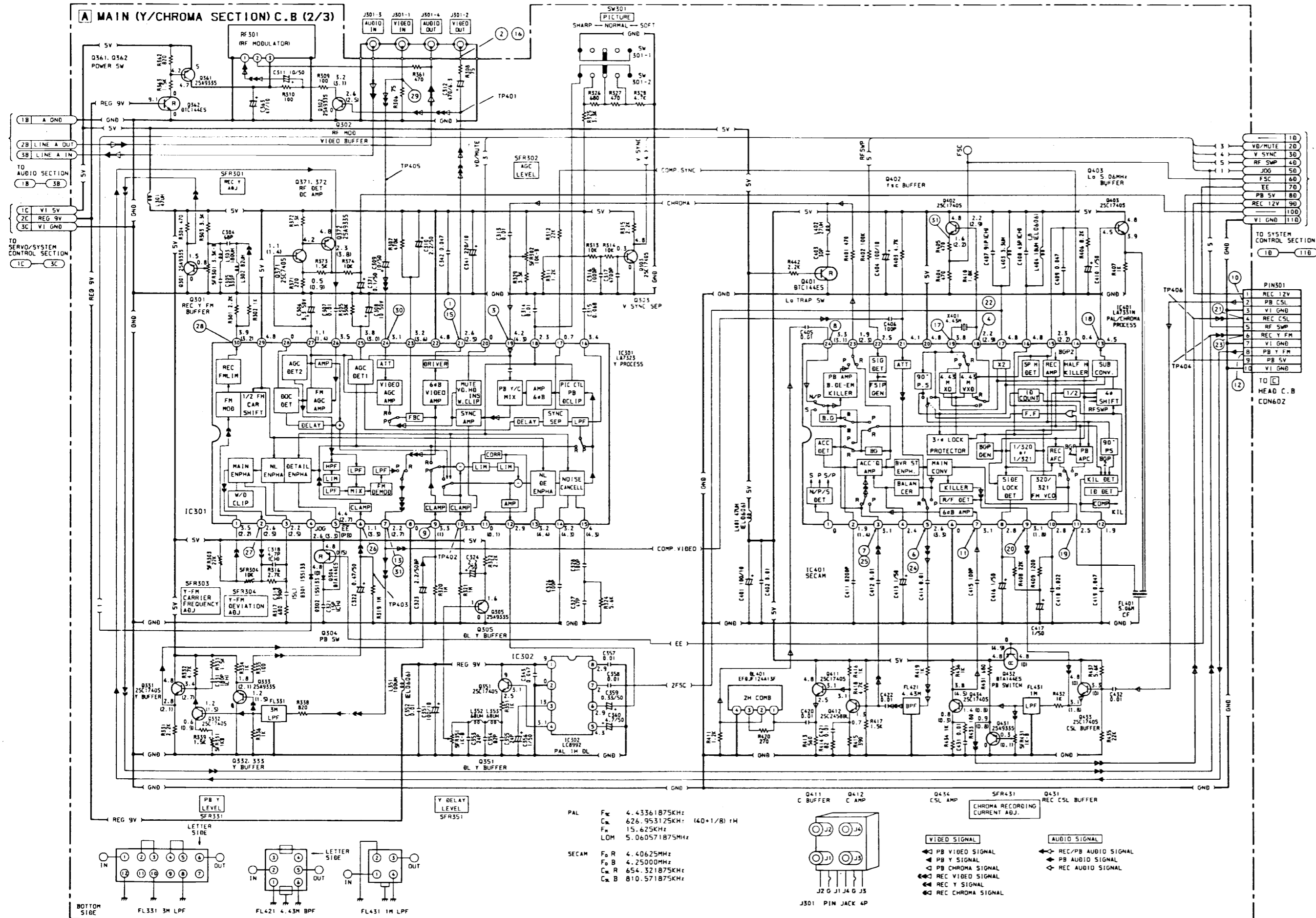

When SYSTEM CONTROL IC has run away SYSTEM CONTROL IC will not accept any mode.

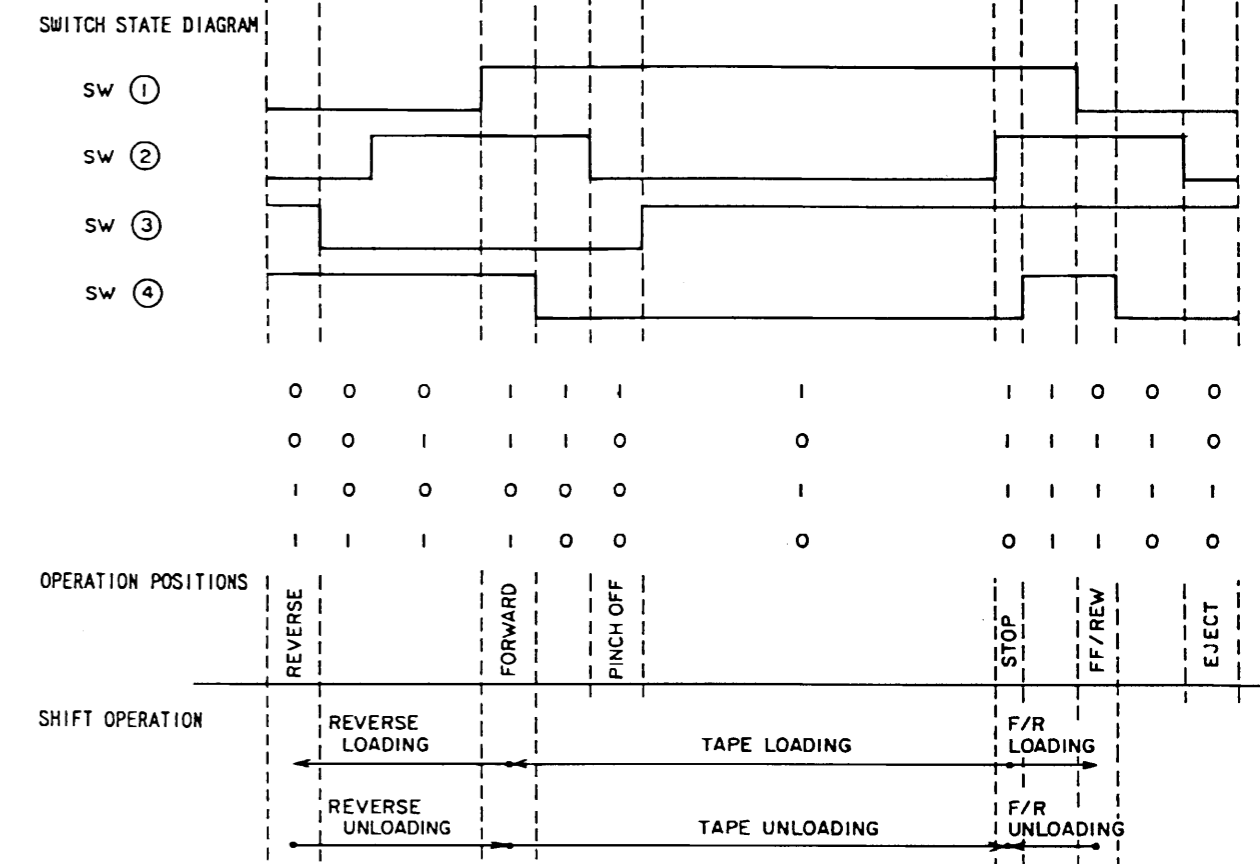
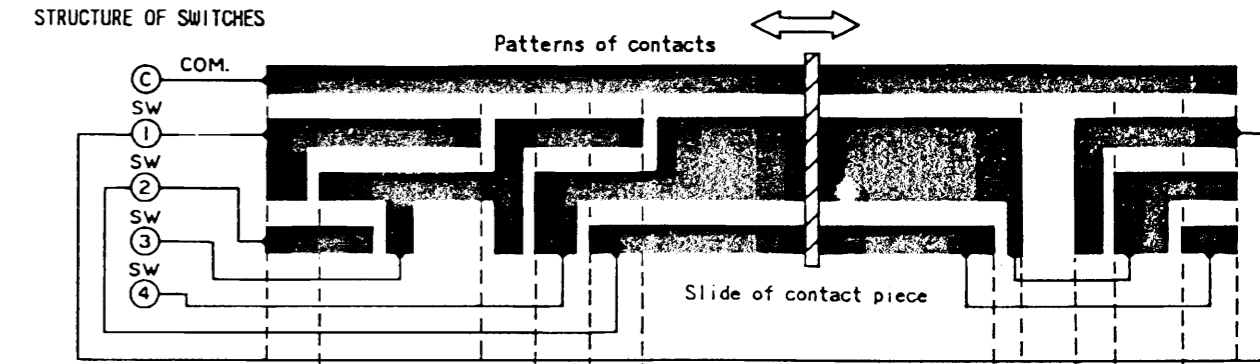

SWITCH				Position
SW1	SW2	SW3	SW4	
0	0	1	0	Front loading, Eject
0	1	1	0	Intermediate
0	1	1	1	F.F, REW
1	1	1	1	Intermediate
1	1	1	0	Stop
1	0	1	0	Tape loading
1	0	0	0	Gear change
1	1	0	0	Intermediate
1	1	0	1	Play (Pause)
0	1	0	1	Intermediate
0	0	0	1	Intermediate
0	0	1	1	Reset

SCHEMATIC DIAGRAM - 2 (SERVO/SYSTEM CONTROL SECTION)

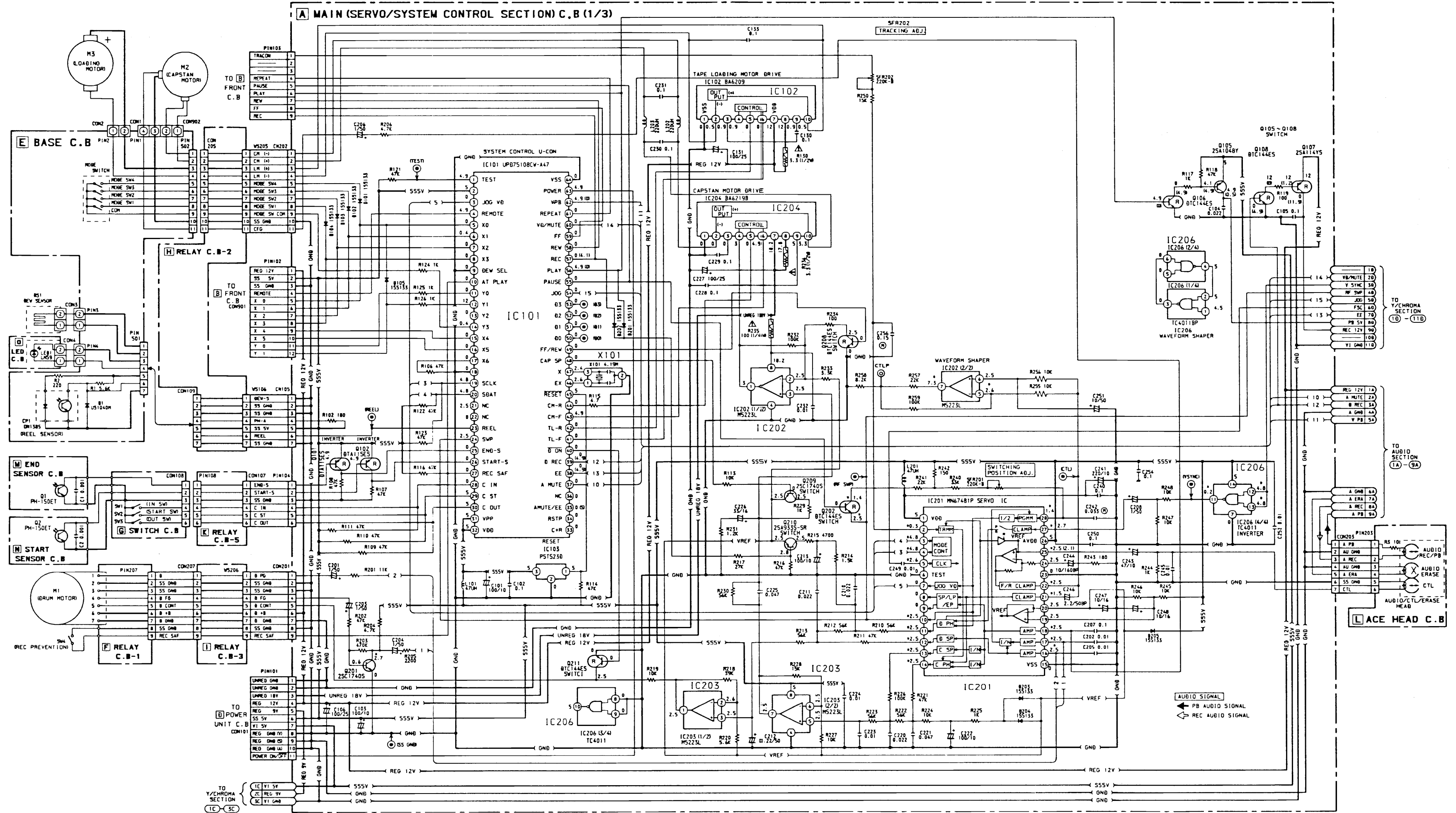

WAVE FORM - 2 (SERVO SECTION)

1. DRUM PG AND FG
 Upper : DRUM PG AC 0.1V/div.
 (IC201 pin ⑩)
 Lower : DRUM FG AC 50mV/div.
 (IC201 pin ⑰)
 Time 5ms/div.

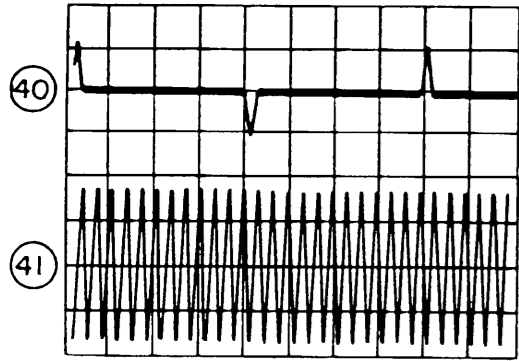

2. DRUM PG AND FG
 Enlargement of 1
 The PG pulse (upper) is generated (either positive or negative) when the FG pulse (lower) is a negative half wave.

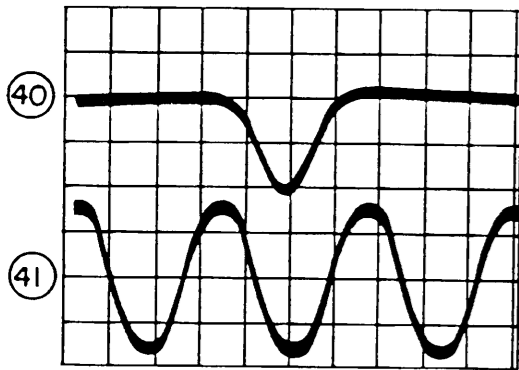

3. CAPSTAN FG (IC201 pin ⑱)
 AC 0.1V/div.
 Time 1ms/div.

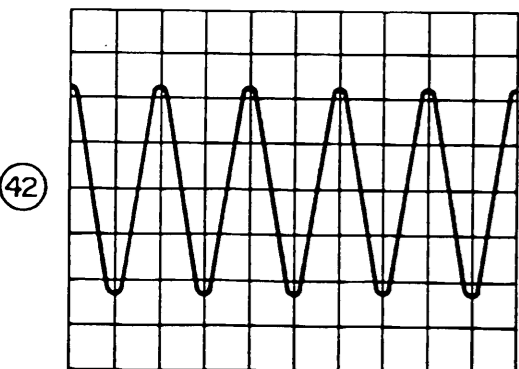

4. RF SW PULSE AND CTL (PB MODE)
 RF SW PULSE DC 1V/div. (IC201 pin ⑩)
 CTL AC 0.5V/div. (IC201 pin ⑳)
 Time 5ms/div.
 The CTL pulse (negative) is 2.3 ± 0.3 ms from the leading edge of the RF SW pulse.

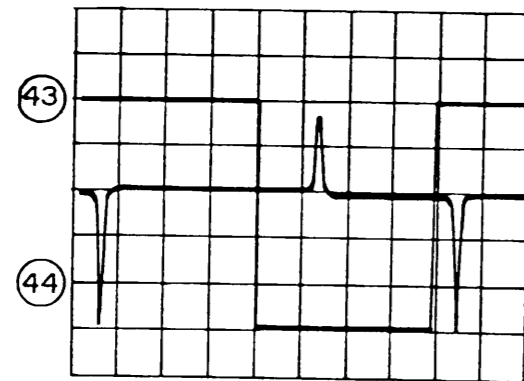

5. RF SW PULSE AND CTL (REC MODE)
 Upper : RF SW PULSE DC 2V/div.
 (IC201 pin ⑩)
 Lower : CTL AC 2V/div.
 (IC201 pin ⑳)
 Time 5ms/div.

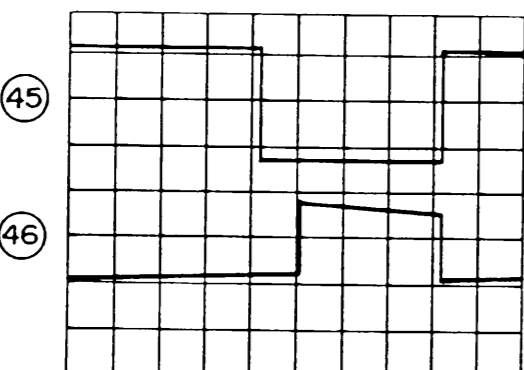

6. RF SW PULSE AND VIDEO OUT
 RF SW PULSE DC 1V/div. (IC201 pin ⑩)
 Video out (OPEN) AC 0.5V/div.
 Time 0.1ms/div.
 The RF SW pulse rises or falls $5 \sim 8H$ ($320 \sim 512 \mu s$) before the VD (vertical sync) signal in the video signal.

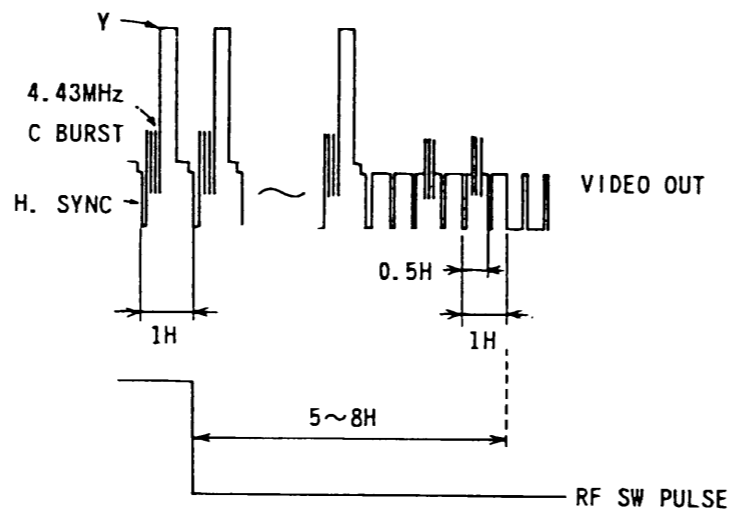
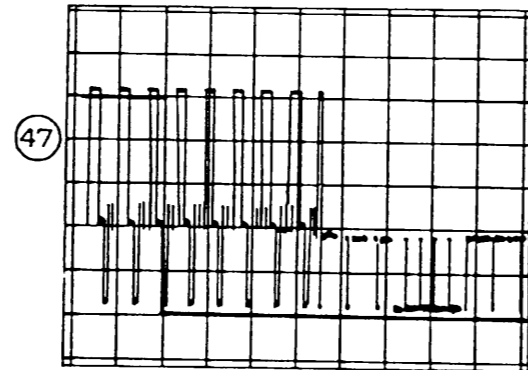

DRUM SERVO SYSTEM TIMING CHART

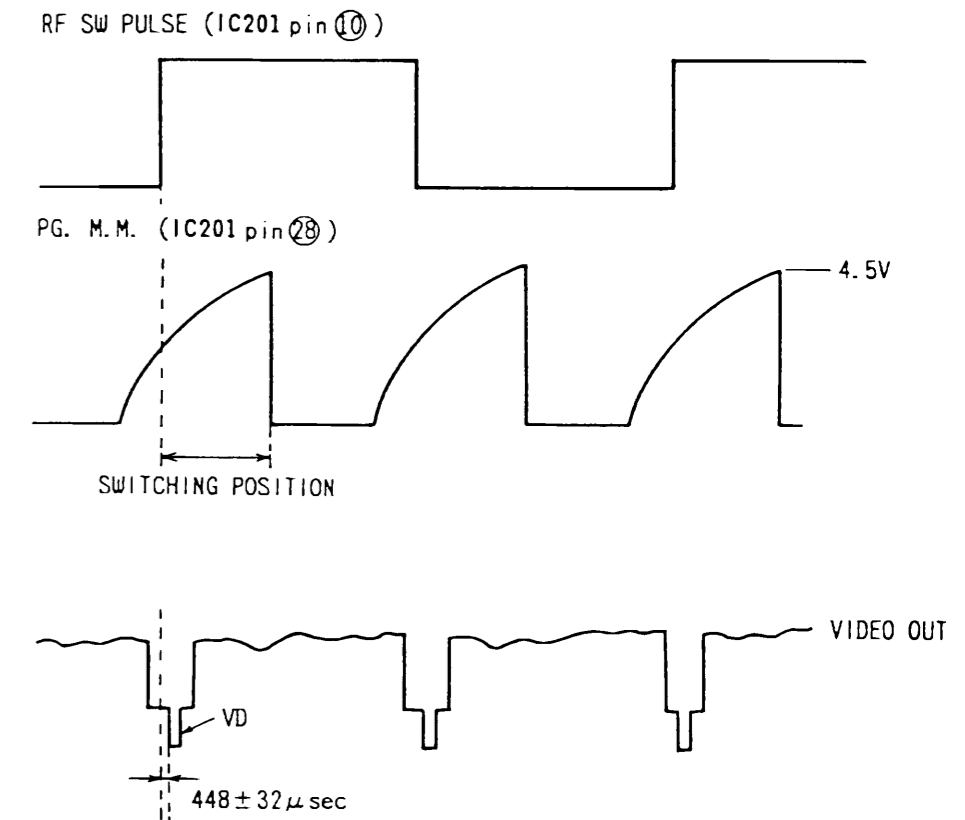
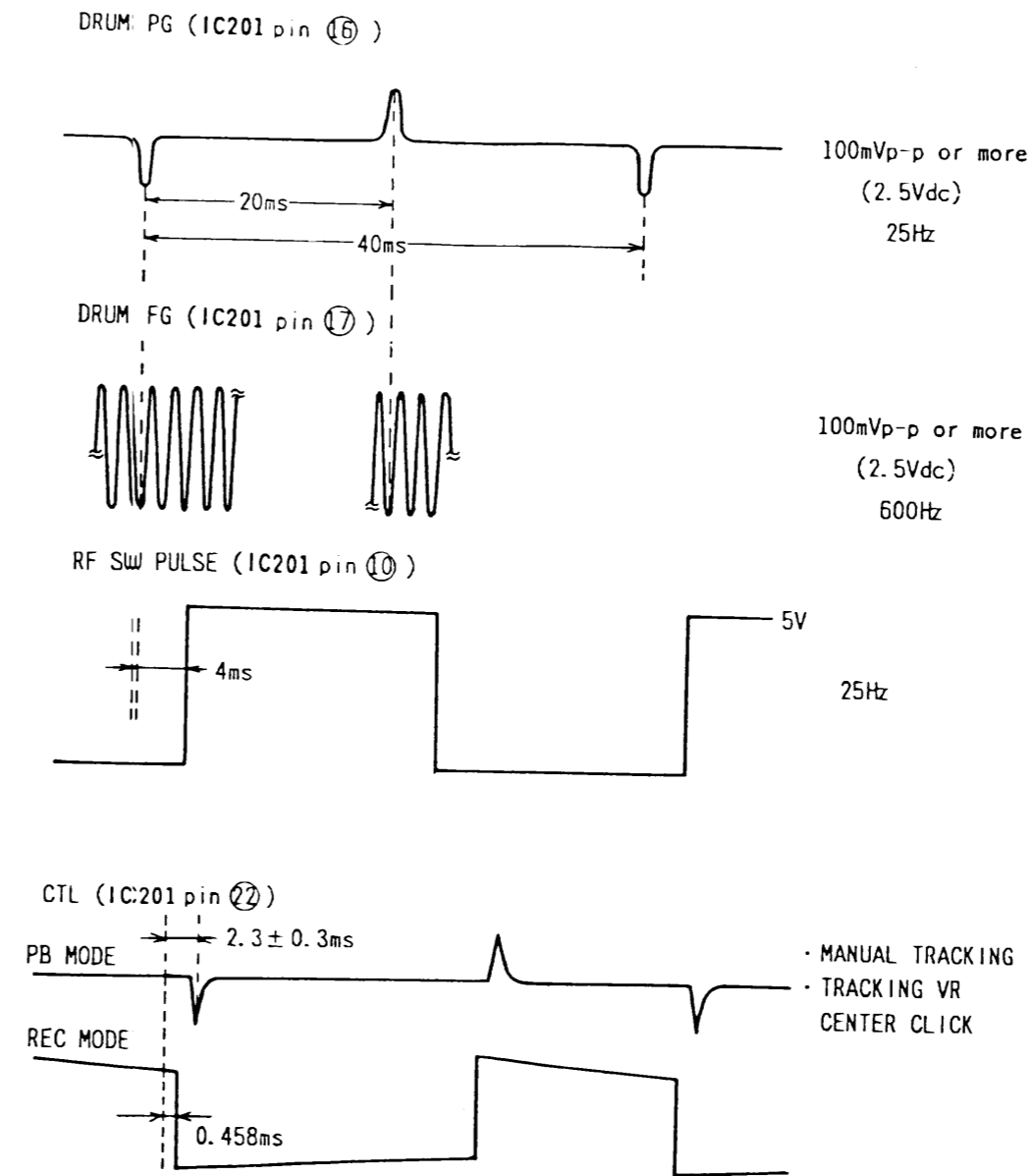

WAVE FORM - 3 (AUDIO SECTION)

T701 pin ①
2 μ s/div.
5V/div.

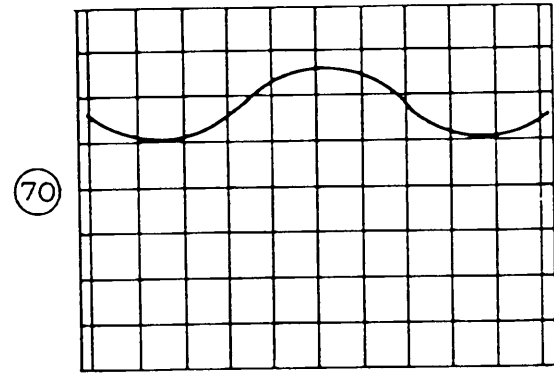

T701 pin ⑥
2 μ s/div.
20V/div.

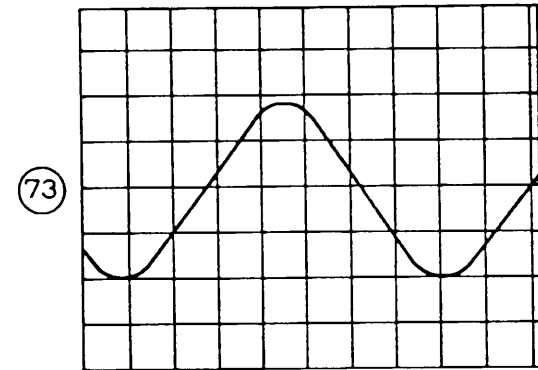

IC701 pins ⑦ and ⑧
200 μ s/div.
20mV/div.

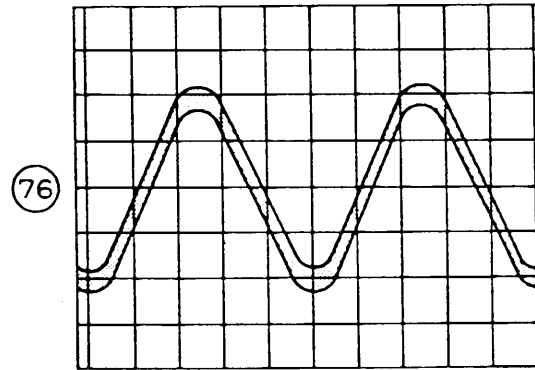

- The wave form shown in the photo on the left is at pins ⑳ and ㉓ of IC701.
- IC701 pin ㉕ is 1.53Vp-p.
200 μ s/div.
50mV/div.

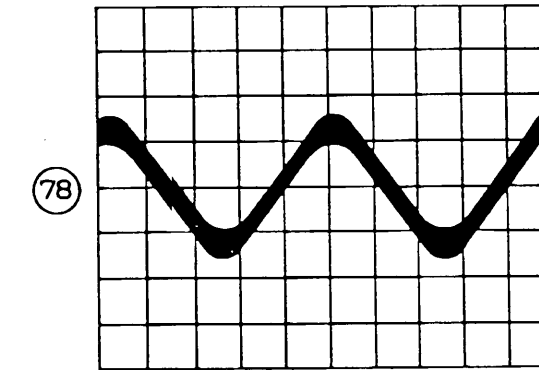

CON602 pin ⑥ (REC)
20 μ s/div.
100mV/div.

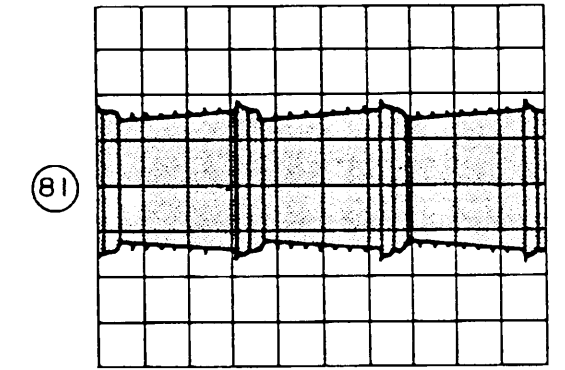

T701 pin ③
2 μ s/div.
10V/div.

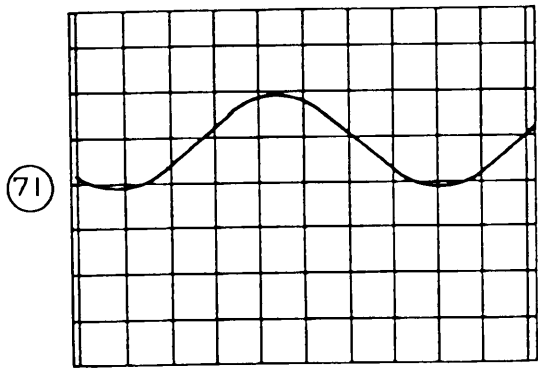

Q701 base
5 μ s/div.
1V/div.

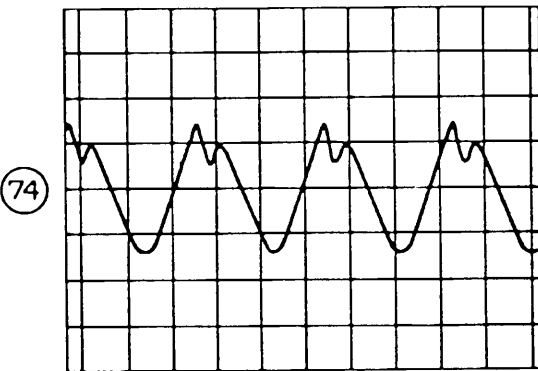

- The wave form shown in the photo on the left is at pin ⑪ of IC701.
- IC701 pins ⑭ to ⑰ are 900mVp-p.
- The specification of the EE level is -8.5 \pm 1dBs when a 1kHz-10dBs signal is input.
500 μ s/div.
20mV/div.

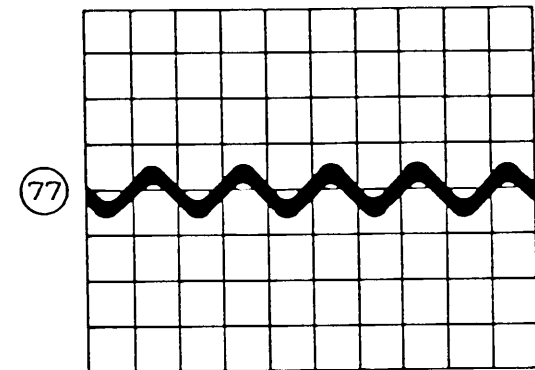

(HEAD AMP SECTION)

CON602 pin ② (PB)
5ms/div.
100mV/div.

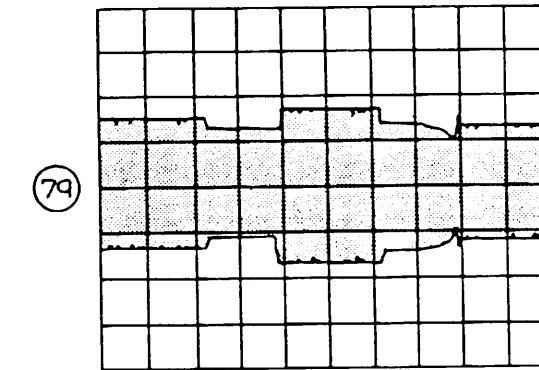

CON602 pin ④ (REC)
20 μ s/div.
20mV/div.

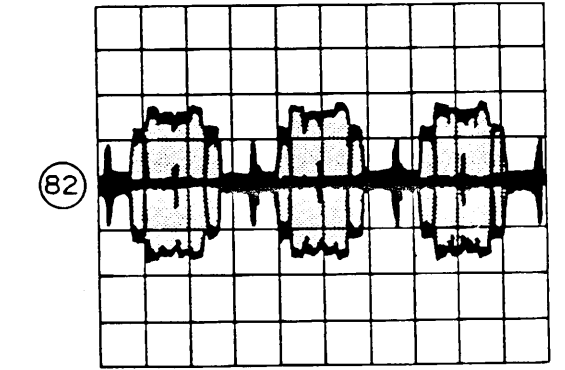

T701 pin ⑤
2 μ s/div.
10V/div.

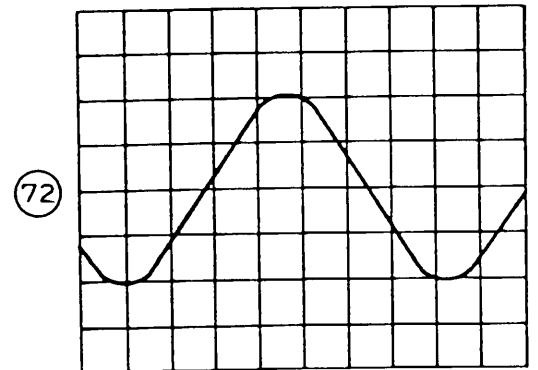

Q701 emitter
5 μ s/div.
500mV/div.

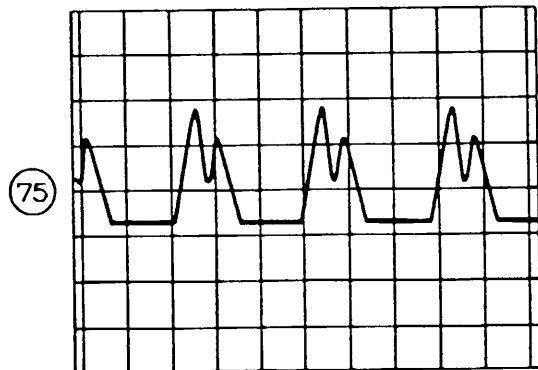

CON602 pin ⑧ (PB)
5ms/div.
200mV/div.

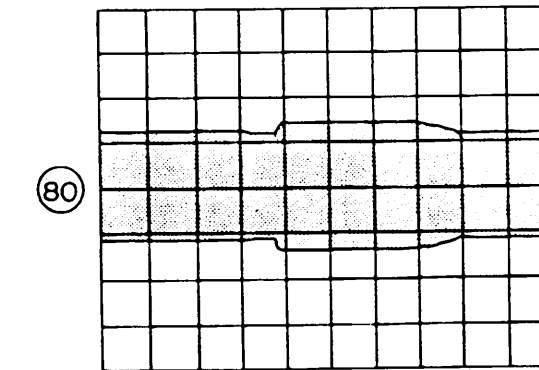

IC610 pin ⑱ (REC)
20 μ s/div.
50mV/div.

